 Z-LASER Optoelektronik GmbH Merzhauser Str. 134 D-79100 Freiburg Tel.: (0761)29644-44 Fax: (0761)29644-55/56	Product <b>Z****Q2-F-808-lp**</b>	Date: <b>2016.04.21</b>	Page: <b>1 of 52</b>
	Advanced Information <b>Document-ID: UI-ZL-100005-Rev0.3.10-2016-04-21</b>		Author: <b>ST</b>



PLEASE READ THE ENTIRE MANUAL BEFORE ATTEMPTING TO OPERATE THIS PRODUCT.

**OPERATING THIS PRODUCT USING PROCEDURES OTHER THAN THOSE SPECIFIED HEREIN MAY RESULT IN HAZARDOUS RADIATION EXPOSURE OR FAILURE.**

AVOID EXPOSURE TO DIRECT OR SCATTERED RADIATION FROM THE LASER.

**It is extremely important to follow laser safety rules and wear appropriate protective eyewear when working around these lasers. As a general rule, you should avoid eye or skin exposure to direct or scattered radiation from these lasers.**

All laser safety-warning labels are provided on the unit and comply with IEC 60825-1

This Product is in full compliance with the European IEC 60825-1 and the United States CDRH laser Safety Regulations.

CAUTION-

**Use of controls or adjustments or performance of procedures other than those specified herein may result in hazardous radiation exposure.**

 Z-LASER Optoelektronik GmbH Merzhauser Str. 134 D-79100 Freiburg Tel.: (0761)29644-44 Fax: (0761)29644-55/56	Product <b>Z****Q2-F-808-1p**</b>	Date: <b>2016.04.21</b>	Page: <b>2 of 52</b>
	Advanced Information <b>Document-ID: UI-ZL-100005-Rev0.3.10-2016-04-21</b>		Author: <b>ST</b>

Revision	Date	Editor	Changes
0.1	12/01/25	Schlägl	Initial Version – documentation of engineering samples
0.1.2	12/02/20	Tempel	Preliminary version for Prototypes
0.2	12/03/08	Tempel	Preliminary version for Prototypes extended
0.2.1	12/04/02	Tempel	Use of external modulation added
0.2.2	12/11/07	Tempel	Correction
0.2.3	12/11/21	Tempel	Minor Corrections
0.2.4	13/02/21	Karakas	Laser Control Connector Pin Description
0.2.5	13/02/25	Schweier	Instruction Firmware update
0.2.6	13/02/27	Tempel	Correction of working range
0.2.7	13/03/14	Tempel	Max. cable length, Heat sink specification
0.2.8	13/03/15	Tempel	Heatsink description change
0.2.9	13/03/21	Tempel	Minor corrections
0.2.10	13/03/22	Schweier	RS232 Commands added
0.3	13/04/11	Tempel	Title
0.3.1	13/04/16	Tempel	Operating conditions corrected
0.3.2	13/04/29	Karakas	Electrical Isolation added, minor corrections
0.3.3	13/10/16	Tempel	Correction of command description for SPS
0.3.4	13/10/22	Tempel	Minor corrections + add on regarding laser safety and system enable.
0.3.5	13/11/20	Tempel	Packaging update, hint about optical performance
0.3.6	13/12/09	Tempel	Update torque specification (heatsink)
0.3.7	14/06/23	Tempel	Keyswitch
0.3.8	15/09/09	Karakas	Overall Corrections and Improvements
0.3.9	15/09/17	Karakas	Heatsink Photographs updated
0.3.10	16/04/21	Schlägl	Date format of revision table, power connector polarity

 Z-LASER Optoelektronik GmbH Merzhauser Str. 134 D-79100 Freiburg Tel.: (0761)29644-44 Fax: (0761)29644-55/56	Product <b>Z****Q2-F-808-lp**</b>	Date: <b>2016.04.21</b>	Page: <b>3 of 52</b>
	Advanced Information <b>Document-ID: UI-ZL-100005-Rev0.3.10-2016-04-21</b>		Author: <b>ST</b>

<b>1</b>	<b>After receiving and delivery .....</b>	<b>5</b>
<b>2</b>	<b>Laser safety.....</b>	<b>6</b>
2.1	Equipment .....	9
2.2	Eye Protection .....	10
2.3	Optical Safety .....	10
2.4	Electrical Safety.....	11
2.5	Emergency Shutdown .....	11
<b>3</b>	<b>General Introduction .....</b>	<b>12</b>
3.1	Handling .....	12
3.2	Optical performance .....	12
3.2.1	Focus: (Simplified).....	12
3.2.2	Line homogeneity .....	13
<b>4</b>	<b>System Information .....</b>	<b>14</b>
4.1	System Features .....	14
4.2	Power Supply Ratings .....	14
4.3	Electrical Isolation.....	14
4.4	Operating Conditions.....	14
<b>5</b>	<b>Installation.....</b>	<b>15</b>
5.1	System Installation Checklist.....	15
5.2	Unpacking and Inspection .....	15
5.3	Laser Mounting.....	16
5.3.1	Laser System Drawings .....	16
5.3.2	Heat Sink Requirements .....	16
5.3.3	Mounting Hardware .....	18
5.3.4	Torque specification .....	18
5.3.5	Power Supply .....	18
5.3.6	Power Supply connection.....	18
5.3.7	RS-232 connection.....	19
5.3.8	Laser Control Connector .....	19
5.3.9	USB connection.....	20
5.3.10	Ethernet connection.....	20
5.3.11	Keypad .....	20
5.3.12	Interlock .....	20
<b>6</b>	<b>Operation.....</b>	<b>23</b>
6.1	Laser Operation checklist.....	23
6.2	Auto-start .....	23
6.3	Laser Warm-up and Standby .....	23
6.4	Shutter Operation .....	24
6.5	No modulation operation .....	24
6.6	Modulation .....	25
6.6.1	Digital TTL-Modulation .....	25
6.6.2	Digital SPS-Modulation .....	25
6.6.3	Use of inverted signals .....	26
6.6.4	Pattern generator.....	26
6.7	LED flashing signals.....	27
<b>7</b>	<b>Remote Operation .....</b>	<b>28</b>

 Z-LASER Optoelektronik GmbH Merzhauser Str. 134 D-79100 Freiburg Tel.: (0761)29644-44 Fax: (0761)29644-55/56	Product <b>Z****Q2-F-808-1p**</b>	Date: <b>2016.04.21</b>	Page: <b>4 of 52</b>
	Advanced Information <b>Document-ID: UI-ZL-100005-Rev0.3.10-2016-04-21</b>		Author: <b>ST</b>

7.1	RS-232 Connection and Setup.....	28
7.2	Command and Query Summary.....	28
7.3	Command Details .....	28
7.4	Commands .....	28
7.4.1	Example Commands .....	30
<b>8</b>	<b>Operation via GUI .....</b>	<b>32</b>
8.1	Supported Operating Systems .....	32
8.2	USB-Stick Contents.....	32
8.3	Installation of ZQ2 Control.....	32
8.4	Exploring ZQ2 Control.....	35
8.4.1	First Steps .....	35
8.4.2	Home Screen.....	37
8.4.3	Temperature Plot.....	43
8.4.4	Pattern Generator.....	43
8.4.5	Temperature Management.....	44
8.4.6	Firmware Update .....	46
<b>9</b>	<b>Troubleshooting Guide.....</b>	<b>48</b>
<b>10</b>	<b>In the case of a damage.....</b>	<b>48</b>
<b>11</b>	<b>Errata .....</b>	<b>49</b>
<b>12</b>	<b>Product Labelling .....</b>	<b>50</b>
<b>13</b>	<b>Accessories .....</b>	<b>51</b>
<b>14</b>	<b>Warranty .....</b>	<b>51</b>
<b>15</b>	<b>Disposal.....</b>	<b>51</b>
<b>16</b>	<b>Declaration of Conformity .....</b>	<b>52</b>

 Z-LASER Optoelektronik GmbH Merzhauser Str. 134 D-79100 Freiburg Tel.: (0761)29644-44 Fax: (0761)29644-55/56	Product <b>Z****Q2-F-808-1p**</b>	Date: <b>2016.04.21</b>	Page: <b>5 of 52</b>
	Advanced Information <b>Document-ID: UI-ZL-100005-Rev0.3.10-2016-04-21</b>		Author: <b>ST</b>

## 1 After receiving and delivery

After receiving this delivery please check carefully the product for potential damage. If you see any damage please report immediately to Z-LASER. In this case do not operate the product!

This shipment contains the following parts:

Package:

1x synthetic case contains:

1x ZQ-2 laser module with laser class and serial number sticker

1x interlock connector with shorted wires

1x keyswitch (jack plug)

1x power supply cable with connector and open leads

1x USB stick with application software "ZQ2 Control" and user manual

If any of these components is missing please contact Z-LASER and do not try to operate the product!

Save the shipping box and packing material for further shipping needs.

(Please see chapter 14)



### CAUTION NOTE

Please note that the Laser module is sensible to Electro Static Discharge. So please take special care for ESD protection.

 Z-LASER Optoelektronik GmbH Merzhauser Str. 134 D-79100 Freiburg Tel.: (0761)29644-44 Fax: (0761)29644-55/56	Product <b>Z****Q2-F-808-lp**</b>	Date: <b>2016.04.21</b>	Page: <b>6 of 52</b>
	Advanced Information <b>Document-ID: UI-ZL-100005-Rev0.3.10-2016-04-21</b>		Author: <b>ST</b>

## 2 Laser safety

Your safety is of high importance to us. Please read and follow the following laser safety information before using this product.

Class 3b and 4 lasers are not intended for use of uneducated personal.



### CAUTION NOTE

The use of optical instruments with this product will increase Eye hazard. Do not shine laser in the direction of other people or at reflective surfaces that might cause exposure to the human eye!

The laser radiation emitted from this unit may be harmful.

Always follow these precautions:

- Avoid direct exposure to the beam.
- Avoid looking at the beam directly.
- Be aware of and follow the warnings on the safety labels
- To completely switch off the unit, unplug the power.
- Make sure that the mechanical shutter of the laser is closed in all cases where the laser output radiation is not required.

Review of reported incidents has demonstrated that accidental eye and skin exposures to laser radiation, and accidents related to the ancillary hazards of a laser or laser system, are most often associated with personnel involved with the use of these systems under the following conditions:

- Unanticipated eye exposure during alignment
- Misaligned optics and upwardly directed beams
- Available eye protection not used
- Equipment malfunction
- Improper methods of handling high voltage
- Unintentional exposure of unprotected personnel
- Operators unfamiliar with laser equipment
- Lack of protection for ancillary hazards

 Z-LASER Optoelektronik GmbH Merzhauser Str. 134 D-79100 Freiburg Tel.: (0761)29644-44 Fax: (0761)29644-55/56	Product <b>Z****Q2-F-808-lp**</b>	Date: <b>2016.04.21</b>	Page: <b>7 of 52</b>
	Advanced Information <b>Document-ID: UI-ZL-100005-Rev0.3.10-2016-04-21</b>		Author: <b>ST</b>

- Improper restoration of equipment following service

These hazards can be avoided by a proper understanding of the equipment and by following safe procedures.

### Equipment.

Test all lasers, delivery systems, and safety equipment prior to turning on the laser. Appropriate personal protective equipment such as appropriate laser protective eyewear has to be worn during such tests. All safety procedures will be followed during service and demonstrations.

### Eye protection.

The greatest risk for personnel using lasers is eye injury to the cornea or retina from direct or reflected laser beams. Protective eyewear with adequate optical density (OD) at the particular wavelength, which is used have to be clearly labelled and worn by all members of the operating team within the NHZ. It is recommended that built-in side shields are used to protect the eyes from tangential beams and scattered reflections. Safety eyewear labelled with the appropriate wavelength and optical density should be available at the entry at every entrance.

**Caution: Laser Safety Eyewear is not designed for looking directly at a laser beam.**

### Checks.

Check the power output of the laser frequently with an appropriate power meter, especially before beginning the procedure. Appropriate eyewear should be worn during such checks. The laser should be placed in a standby mode when not in use, to prevent inadvertent exposure to power/energy.

### Electrical Hazards.

Use of any electrical system may give rise to electrical hazards; consequently, proper grounding and insulation are imperative. Protection against accidental contact with energized conductors by means of a barrier system is the primary methodology to prevent electric shock accidents with laser equipment. Additional electrical safety requirements are imposed upon laser devices, systems, and those who work with

 Z-LASER Optoelektronik GmbH Merzhauser Str. 134 D-79100 Freiburg Tel.: (0761)29644-44 Fax: (0761)29644-55/56	Product <b>Z****Q2-F-808-lp**</b>	Date: <b>2016.04.21</b>	Page: <b>8 of 52</b>
	Advanced Information <b>Document-ID: UI-ZL-100005-Rev0.3.10-2016-04-21</b>		Author: <b>ST</b>

them, by the US Department of Labor, OSHA, the National Electrical Code (NFPA 70), and related state and local laws and regulations. These requirements govern equipment connection to the electrical utilization system, electrical protection parameters, and specific safety training. These requirements must be observed with all laser installations.

The following potential problems have frequently been identified during laser facility audits.

- Uncovered electrical terminals
- Improperly insulated electrical terminals
- Hidden “power-up” warning lights
- Lack of personnel trained in current cardiopulmonary resuscitation practices, or lack of refresher training
- “Buddy system” not being practiced during maintenance and service
- Non earth-grounded or improperly grounded laser equipment
- Non-adherence to the OSHA lock-out standard (29 CFR 1910.147)
- Excessive wires and cables on floor that create fall or slip hazards

### **Emergency Shutdown.**

An emergency shutdown switch must be available to the operator or the assistant for rapid emergency shutdown of the equipment. The interlock of the laser is intended to shut down laser power immediately

### **Controlled Area.**

Authorized personnel, upon entry to an area where lasers are used, should be provided with personal protective equipment (see Description of Facilities, above). Such controlled area should contain the NHZ, the extent of which is clearly delineated, and should be posted with appropriate laser warning signs specific to the wavelength being used (as described in ANSI Z136.3, Section 4.7). The laser should not be activated when it is necessary to open the door, if the Nominal Hazard Zone (NHZ) extends to the doorway.

Glass windows will be covered with shades or filters of appropriate optical density whenever a fibre optic laser system is operational. No one is allowed in a laser room unless properly authorized and protected.



 Z-LASER Optoelektronik GmbH Merzhauser Str. 134 D-79100 Freiburg Tel.: (0761)29644-44 Fax: (0761)29644-55/56	Product <b>Z****Q2-F-808-1p**</b>	Date: <b>2016.04.21</b>	Page: <b>9 of 52</b>
	Advanced Information <b>Document-ID: UI-ZL-100005-Rev0.3.10-2016-04-21</b>		Author: <b>ST</b>

## Warning Signs.

Regulation Danger laser signs will be posted at eye level on all doors that access a room where Class 3b and/or Class 4 laser will be operated. These signs will state all required information as described in the ANSI Z136.1 standard, and will be removed when the laser is not in use.

## Fire Hazards.

Class 4 laser systems represent a fire hazard. Enclosure of Class 4 laser beams can result in potential fire hazards if enclosure materials are likely to be exposed to irradiances exceeding 10 W/cm<sup>2</sup> or beam powers exceeding 0.5 W. The use of flame retardant materials, as defined by the National Fire Protection Association (NFPA), should be encouraged.

Opaque laser barriers e.g., curtains, can be used to block the laser beam from exiting the work area during certain operations. While these barriers can be designed to offer a range of protection, they normally cannot withstand high irradiance levels for more than a few seconds without some damage, e.g., production of smoke, open fire, or penetration. Users of commercially available laser barriers should obtain appropriate fire prevention information from the manufacturer.

Operators of Class 4 lasers should be aware that unprotected wire insulation and plastic tubing can catch fire from intense reflected or scattered beams, particularly from lasers operating at invisible wavelengths.

## Explosion Hazards

High-pressure arc lamps, filament lamps, and capacitor banks in laser equipment shall be enclosed in housings, which can withstand the maximum explosive pressure resulting from component disintegration. The laser target and elements of the optical train which may shatter during laser operation shall also be enclosed or equivalently protected to prevent injury to operators and observers. Explosive reactions of chemical laser reactants or other laser gases may be a concern in some cases.

## 2.1 Equipment

### Ready indicator

The Z-Laser ZQ-2 laser system includes a ready indicator on the back side of the laser, opposite to the aperture. If the laser is connected correctly to the power supply and the shutter is closed, the ready LED will blink, if the shutter is open, then the ready LED will be illuminated constantly.

 Z-LASER Optoelektronik GmbH Merzhauser Str. 134 D-79100 Freiburg Tel.: (0761)29644-44 Fax: (0761)29644-55/56	Product <b>Z****Q2-F-808-lp**</b>	Date: <b>2016.04.21</b>	Page: <b>10 of 52</b>
	Advanced Information <b>Document-ID: UI-ZL-100005-Rev0.3.10-2016-04-21</b>		Author: <b>ST</b>

### **Laser on/off indicator**

The laser indicator LED on the back side is illuminated, if the laser is on. In modulation mode the LED may flicker in the same way the modulation is set, if the frequency is no to high.

### **Interlock**

If the interlock is not shortened, the laser will not work. An error will be displayed as blinking code on the laser backside as well as an error indicator in the GUI.

### **Keyswitch**

If the keyswitch is not connected to the laser, no laser operation is possible. An error will be displayed as blinking code on the laser backside as well as an error indicator in the GUI.

### **System enable**

If system is not enabled in external modulation mode an error will be displayed as blinking code on the laser backside until enabled is set.

### **IMPORTANT:**

Based on the IEC 60825-1:2007 safety standard for laser products, it is obligatory to use a separate power system to enable supply voltage to turn the laser power on. You are NOT allowed to connect the power supply voltage to the system enable pin to avoid additional actions for turning the laser on (emitting laser radiation) ! It is your responsibility to operate the laser by actively and manually setting the system enable on function.

Z-LASER GmbH (and its subsidiaries) does not accept responsibility for any violation of this rule that make cause possible damage to personnel and/or materials.

### **Shutter**

At the front side of the laser beside the aperture the handle of the mechanical shutter is placed. When closed (pushed towards the aperture) the laser is closed.

When shutter is closed during laser operation the laser shuts its self down after 10s, but restarts laser operation instantly after the re-opening of the shutter.

## **2.2 Eye Protection**

Always wear proper eye protection. Be sure, that the wavelength of the laser and the protection band of your protective eye wear match and that the attenuation for this wavelength is high enough.

## **2.3 Optical Safety**

Based on the properties associated with laser light, special optical safety precautions are recommended by Z-Laser GmbH. Direct eye exposure from the laser light emitted from the output aperture located on the front of the laser head is considered dangerous.

 Z-LASER Optoelektronik GmbH Merzhauser Str. 134 D-79100 Freiburg Tel.: (0761)29644-44 Fax: (0761)29644-55/56	Product <b>Z****Q2-F-808-lp**</b>	Date: <b>2016.04.21</b>	Page: <b>11 of 52</b>
	Advanced Information <b>Document-ID: UI-ZL-100005-Rev0.3.10-2016-04-21</b>		Author: <b>ST</b>

Z-Laser GmbH recommends the use of proper laser safety eyewear when operating the laser system.

This means, that the used laser safety eyewear offers for the emitting wavelength and maximum output power of the laser enough safety. Also be sure, that no reflections on any surface can harm you or someone else.

Always exercise caution when operating or working with lasers!

## 2.4 Electrical Safety

No hazardous voltages are contained in the laser head. The system does not contain any user accessible components within the laser head. The warranty will void if the laser or enclosures are disassembled.

### ESD

It is recommended to take proper ESD precautions when handling the laser. The laser system is designed with internal safeguards for protection from ESD. Never the less high energy ESD discharge events may cause damage to the laser system.

## 2.5 Emergency Shutdown

The system shuts its self down, if an error occurs. This means, that no laser light is emitted from the optic head.

Possible errors are:

- Temperature failure
- Interlock open
- Keyswitch missing
- System not enabled (only possible at external modulation)

Depending on the operation mode different actions are necessary to start the laser again.

### GUI-Mode

After eliminating the occurred error mentioned above use the “laser on” button in the GUI to start laser operation again.

For other malfunctions a total restart of the system is necessary.

### External modulation

After eliminating the occurred error mentioned above set a low-high-flank at system enable to start the laser operation again.

For other malfunction a total restart of the system is necessary.

 Z-LASER Optoelektronik GmbH Merzhauser Str. 134 D-79100 Freiburg Tel.: (0761)29644-44 Fax: (0761)29644-55/56	Product <b>Z****Q2-F-808-lp**</b>	Date: <b>2016.04.21</b>	Page: <b>12 of 52</b>
	Advanced Information <b>Document-ID: UI-ZL-100005-Rev0.3.10-2016-04-21</b>		Author: <b>ST</b>

### 3 General Introduction

#### 3.1 Handling

Always handle with care.

#### 3.2 Optical performance

##### 3.2.1 Focus: (Simplified)

The farther the laser is focused, the larger the beam diameter (line thickness) gets. Vice versa, the closer the focus to the laser, the smaller the beam diameter (line thickness) gets. This is obviously limited due to the laws of physics.

Further explanation:

To focus a laser a lens has to be moved coaxial either towards the source (focus at far distance) or away from the source (focus at near distance).

The closer the lens is at the source the smaller the beam diameter into the lens gets and the farther away the lens is of the source, the larger the beam diameter gets.

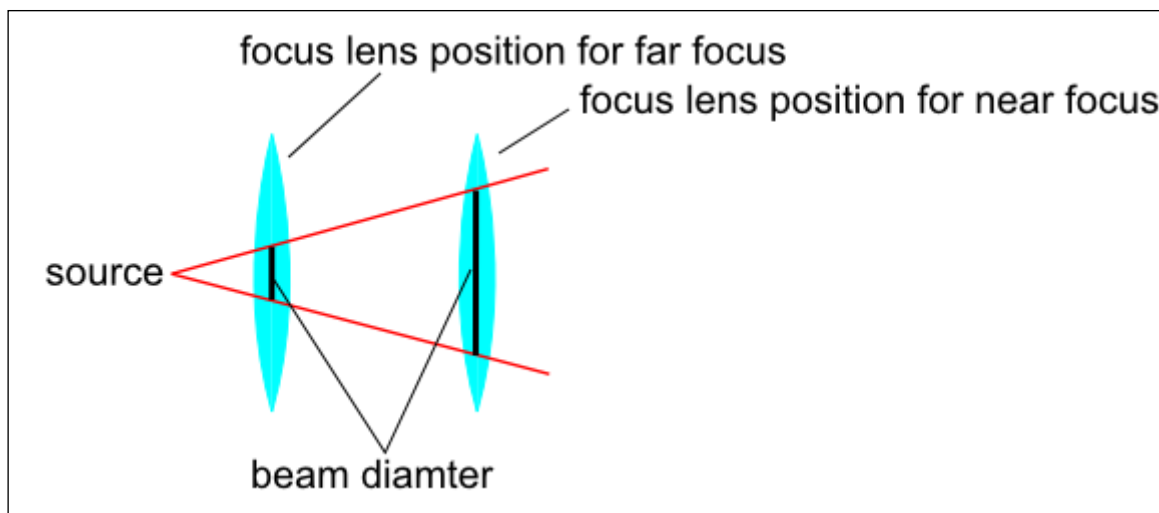

Due to diffraction limitation the small beam diameter will create a larger focus (line thickness) than the larger beam diameter, which creates a smaller focus (line thickness).

 Z-LASER Optoelektronik GmbH Merzhauser Str. 134 D-79100 Freiburg Tel.: (0761)29644-44 Fax: (0761)29644-55/56	Product <b>Z****Q2-F-808-lp**</b>	Date: <b>2016.04.21</b>	Page: <b>13 of 52</b>
	Advanced Information <b>Document-ID: UI-ZL-100005-Rev0.3.10-2016-04-21</b>		Author: <b>ST</b>

### 3.2.2 Line homogeneity

(Simplified)

By changing the focus the homogeneity of the line will change. The super elevation on the outer sides of the line will raise or fall due to the focus distance.

This is due to changes in the beam diameter entering the line generator.

 Z-LASER Optoelektronik GmbH Merzhauser Str. 134 D-79100 Freiburg Tel.: (0761)29644-44 Fax: (0761)29644-55/56	Product <b>Z****Q2-F-808-1p**</b>	Date: <b>2016.04.21</b>	Page: <b>14 of 52</b>
	Advanced Information <b>Document-ID: UI-ZL-100005-Rev0.3.10-2016-04-21</b>		Author: <b>ST</b>

## 4 System Information

### 4.1 System Features

- All-in-one case solution with integrated optics, electronics and active temperature control
- IR 808nm wavelength available up to 6.2W
- Extraordinary stability, completely sealed optics
- Multiple projections available including fibre, homogenous line projection, collimated beam, structured light
- User adjustable hand focusing mechanism
- Bore sight accuracy < 3 mrad
- Modulation up to 10 kHz
- Interfaces: RS232, USB, Ethernet, PLC
- 24VDC power supply
- Wide range operation temperature 0°C to 50°C
- Wavelength drift max. +/- 1nm over entire operating temperature range

### 4.2 Power Supply Ratings

- Power Supply: 24 VDC, 4A min. (100W) capable power supply needed
- Power cable length: 2m max., to limit possible parasitic inductivities/capacitances on the power line.

### 4.3 Electrical Isolation

- USB Interface: 2.5kV full galvanic isolation (digital transformer isolation)
- RS232 Interface: 2.5kV full galvanic isolation (digital transformer isolation)
- System Enable, Laser On and Fail Out: 2.5kV full galvanic isolation (digital transformer isolation)

### 4.4 Operating Conditions

Operating temperatures at base plate: 0°C to 50°C

Storage temperatures: -20°C to 70°C

 Z-LASER Optoelektronik GmbH Merzhauser Str. 134 D-79100 Freiburg Tel.: (0761)29644-44 Fax: (0761)29644-55/56	Product <b>Z****Q2-F-808-1p**</b>	Date: <b>2016.04.21</b>	Page: <b>15 of 52</b>
	Advanced Information <b>Document-ID: UI-ZL-100005-Rev0.3.10-2016-04-21</b>		Author: <b>ST</b>

## 5 Installation

### 5.1 System Installation Checklist

- Unpack and inspect ZQ2 laser module
- Use 4 x M6 or 4 x 1/4" – 20 mounting screws to secure ZQ2 laser module to an appropriate heatsink
- Plug in keyswitch and interlock connector into the rear panel sockets
- Connect ZQ2 laser module to an appropriate power supply
- Plug in auxiliary adapter for setting "SysEnable" and "modulation" to high (if used for external modulation)
- Connect RS-232 cable for control via PC
- Proceed to chapter 6 Operation for additional information

### 5.2 Unpacking and Inspection

After receiving this delivery please check carefully the product for potential damage. If you see any damage please report immediately to Z-LASER. In this case do not operate the product!

The ZQ2 laser module shipment will include the following items:

- ZQ2 laser module with focus head (1 piece)
- Keyswitch
- Interlock connector
- Connection Cable for Power Supply
- USB-Stick including the software "ZQ2 Control"
- User manual (possibly digital version on USB-stick)

 Z-LASER Optoelektronik GmbH Merzhauser Str. 134 D-79100 Freiburg Tel.: (0761)29644-44 Fax: (0761)29644-55/56	Product <b>Z****Q2-F-808-1p**</b>	Date: <b>2016.04.21</b>	Page: <b>16 of 52</b>
	Advanced Information <b>Document-ID: UI-ZL-100005-Rev0.3.10-2016-04-21</b>	Author: <b>ST</b>	

## 5.3 Laser Mounting

### 5.3.1 Laser System Drawings

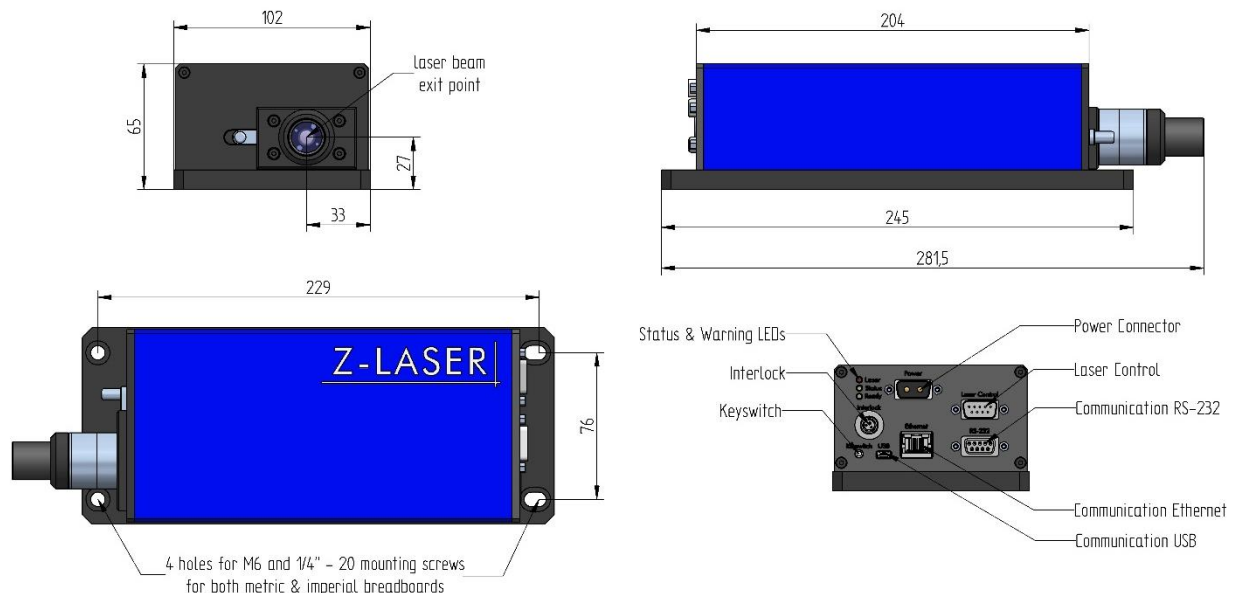

### 5.3.2 Heat Sink Requirements

The ZQ2 laser module is conduction cooled and requires a heat sink for operation.

- Failure to use a heat sink will overheat the laser module
- A Heat sink compound may improve the heat transfer if the heatsink surface is rough.
- A heat sink capable of dissipating 225 Watts is required for laser mounting
- A 32 finish is recommended for the laser mounting surface, to ensure optimum thermal transfer
- A high tolerance heat sink surface flatness is recommended for laser head mounting

Supplement to the above mentioned requirements:

The higher the environmental temperature is, the bigger or better the heat sink has to be.

To cool a heat sink you need at least moving air (convictional cooling) and a large surface which can get in contact with the “wind”. The bigger the surface and the faster your air moves along this surface the more you cool it. (The environmental air



 Z-LASER Optoelektronik GmbH Merzhauser Str. 134 D-79100 Freiburg Tel.: (0761)29644-44 Fax: (0761)29644-55/56	Product <b>Z***Q2-F-808-lp**</b>	Date: <b>2016.04.21</b>	Page: <b>17 of 52</b>
	Advanced Information <b>Document-ID: UI-ZL-100005-Rev0.3.10-2016-04-21</b>		Author: <b>ST</b>

has to be cooler than the laser system or the heat sink otherwise you heat the heat sink and the laser up.)

If you use the laser indoor in a closed (and small) area (e.g. in a closed machine) you need artificially ventilated heat sink.

Possibly your machine, in which your ZQ-2 is installed heats the environment (and there fore the air which is used to cool the laser) up, you need a bigger heat sink and / or more powerful fan attached to the heat sink.

Another option is a liquid cooled heat sink. The advantage is that it can be smaller at the laser itself, but it needs a heat exchanging system connected to it.

To illustrate what is meant some examples:

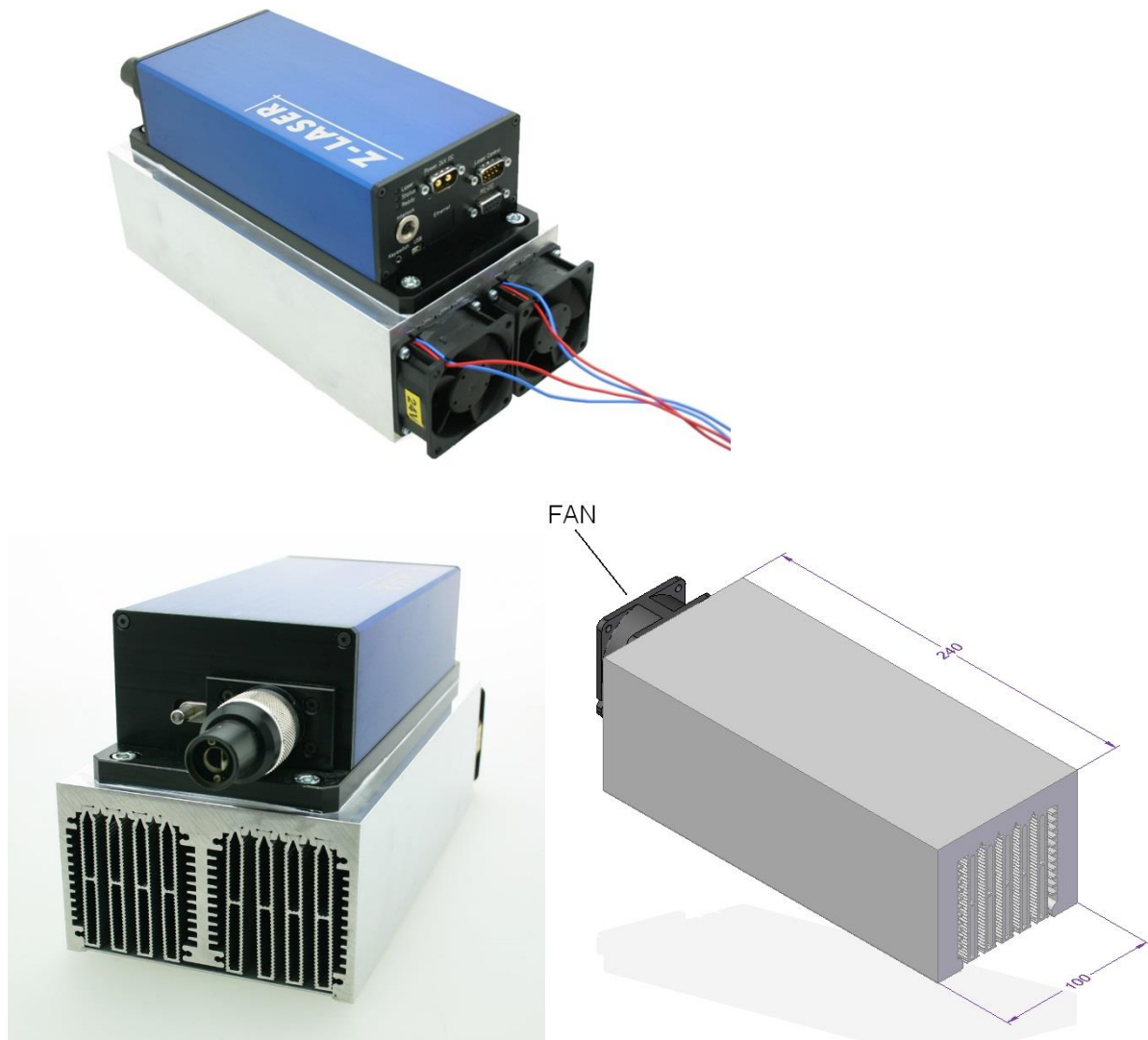

 Z-LASER Optoelektronik GmbH Merzhauser Str. 134 D-79100 Freiburg Tel.: (0761)29644-44 Fax: (0761)29644-55/56	Product <b>Z****Q2-F-808-lp**</b>	Date: <b>2016.04.21</b>	Page: <b>18 of 52</b>
	Advanced Information <b>Document-ID: UI-ZL-100005-Rev0.3.10-2016-04-21</b>		Author: <b>ST</b>

### 5.3.3 Mounting Hardware

For mounting the ZQ2 laser module on an appropriate heatsink use either 4 x M6 or 4 x 1/4" -20 mounting screws with washers.

Always use washers for laser head mounting, to reduce base plate stress and avoid damage to the mounting holes.

### 5.3.4 Torque specification

Normal mounting can be accomplished by using a standard Allen key to secure the laser head to the heat sink, by tightening the screws gradually in a progressing cross pattern. This method should provide stable thermal and pointing performance. Optimum thermal and pointing performance is accomplished by securing the laser head to the heat sink, with a precision torque wrench. Torque the laser head to the heat sink by using a cross torque pattern and progressively increasing torque from up to 6 Nm.

### 5.3.5 Power Supply

To operate the ZQ2 laser module connect it to a power supply unit capable of a +24V DC output voltage with a minimum of 4A current rating.

### 5.3.6 Power Supply connection

Each ZQ2 laser module is shipped with a mixed SUB-D power cable. This cable is available at most customer electronic stores. Before enabling the power supply make sure that the power pins are connected as described in the figure below.

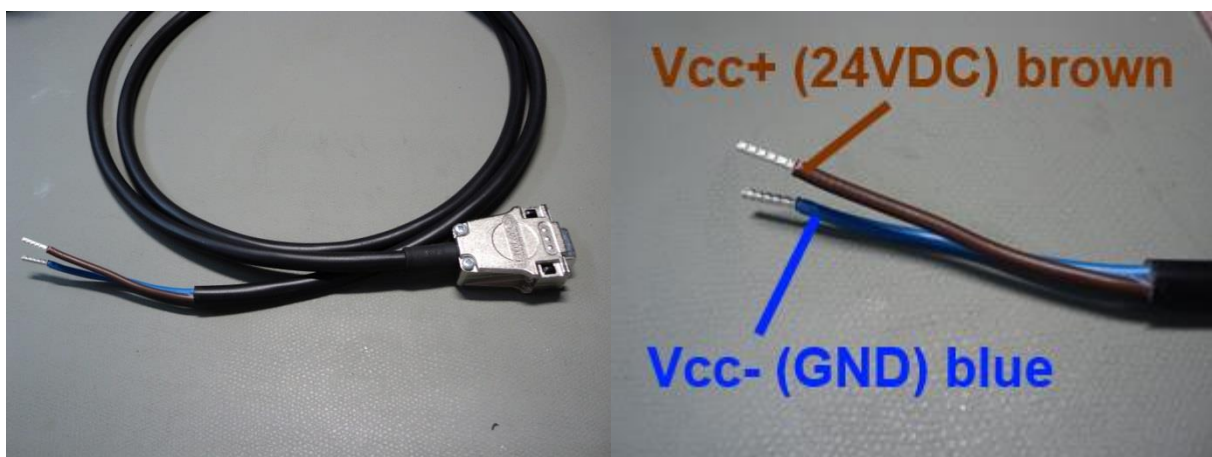

 Z-LASER Optoelektronik GmbH Merzhauser Str. 134 D-79100 Freiburg Tel.: (0761)29644-44 Fax: (0761)29644-55/56	Product <b>Z****Q2-F-808-1p**</b>	Date: <b>2016.04.21</b>	Page: <b>19 of 52</b>
	Advanced Information <b>Document-ID: UI-ZL-100005-Rev0.3.10-2016-04-21</b>	Author: <b>ST</b>	

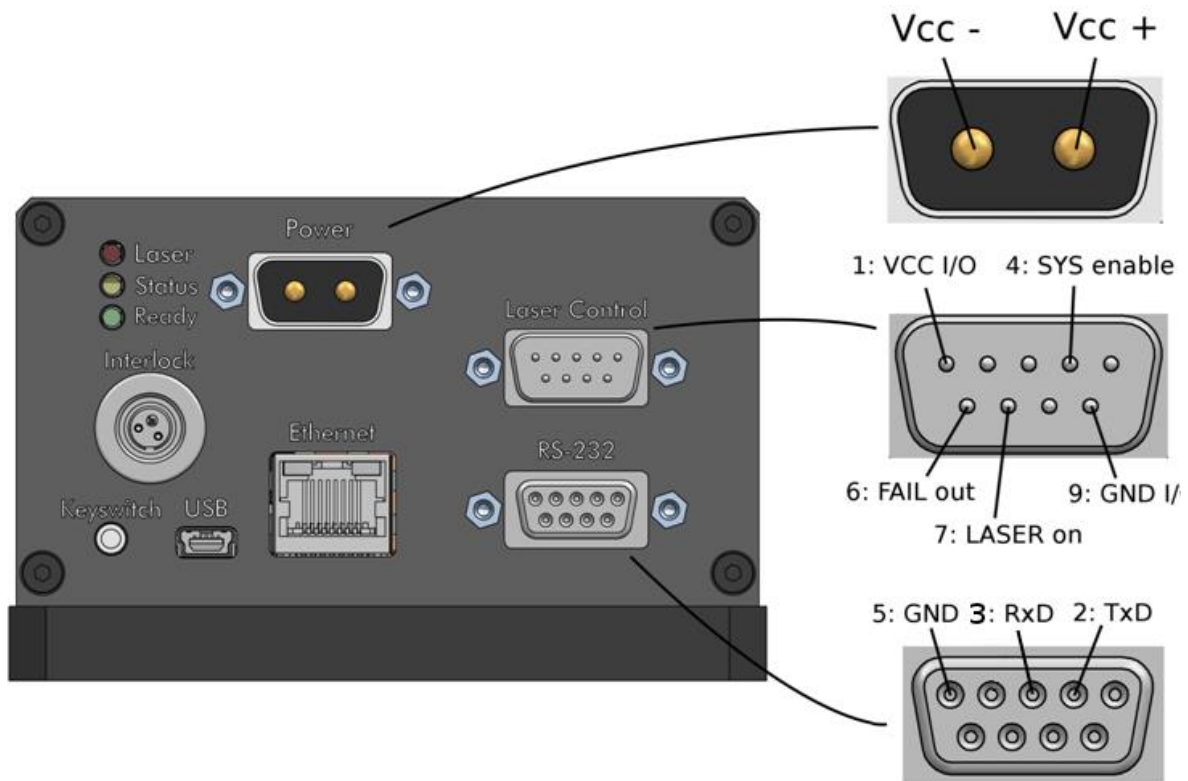

### 5.3.7 RS-232 connection

The RS-232 connection is used for communication with the GUI. See chapter 8 for further information.

### 5.3.8 Laser Control Connector

The Laser Control 9-pin D-Sub connector is used for modulating the laser via a function generator. It also serves as status indicator FAIL OUT output, which is pulled low in case of an error. Control inputs SYS ENABLE and LASER ON allow the user to externally turn on the laser and enable the overall laser control, respectively.

**Pin 1:** VCC I/O

**Pin 2:** NC

**Pin 3:** NC

**Pin 4:** System Enable Input

**Pin 5:** NC

**Pin 6:** FAILURE Output (**Active Low**)

**Pin 7:** Laser ON Input

**Pin 8:** NC

**Pin 9:** GND

 Z-LASER Optoelektronik GmbH Merzhauser Str. 134 D-79100 Freiburg Tel.: (0761)29644-44 Fax: (0761)29644-55/56	Product <b>Z****Q2-F-808-1p**</b>	Date: <b>2016.04.21</b>	Page: <b>20 of 52</b>
	Advanced Information <b>Document-ID: UI-ZL-100005-Rev0.3.10-2016-04-21</b>		Author: <b>ST</b>

Connect Pin 1 (VCC I/O) to +24V to be able to read out errors at Pin 6 in SPS logic level (+24V). Refer to Section 6.6.2 for details.

### 5.3.9 USB connection

Not functional yet.

### 5.3.10 Ethernet connection

Not functional yet.

### 5.3.11 Keyswitch

Do not, under any circumstances manipulate the keyswitch, and do not try to plug anything else in the therefore intended connector of the laser housing.

If your keyswitch is broken or lost, contact Z-LASER for substitution.



The keyswitch

### 5.3.12 Interlock

The interlock has to be shortened to ensure any laser operation. Please modify the interlock for your purposes.

The interlock is screwed into the backside of the housing into the therefore intended connector. There is only one correct possibility to insert the plug into the housing. Do not use force!

 Z-LASER Optoelektronik GmbH Merzhauser Str. 134 D-79100 Freiburg Tel.: (0761)29644-44 Fax: (0761)29644-55/56	Product <b>Z****Q2-F-808-lp**</b>	Date: <b>2016.04.21</b>	Page: <b>21 of 52</b>
	Advanced Information <b>Document-ID: UI-ZL-100005-Rev0.3.10-2016-04-21</b>		Author: <b>ST</b>



The front side of the interlock, which will be inserted into the housing, is a screw.

To do any manipulations at the interlock remove the silver cap while pressing the two lashes at the side off the interlock towards the centre (see red arrows).



Use the below showed internal pins (here shortened with yellow cable) to modify the interlock for safety application in your process.

<b>Z-LASER</b> <small>Z-LASER Optoelektronik GmbH Merzhauser Str. 134 D-79100 Freiburg Tel.: (0761)29644-44 Fax: (0761)29644-55/56</small>	Product <b>Z****Q2-F-808-lp**</b>	Date: <b>2016.04.21</b>	Page: <b>22 of 52</b>
	Advanced Information <b>Document-ID: UI-ZL-100005-Rev0.3.10-2016-04-21</b>	Author: <b>ST</b>	

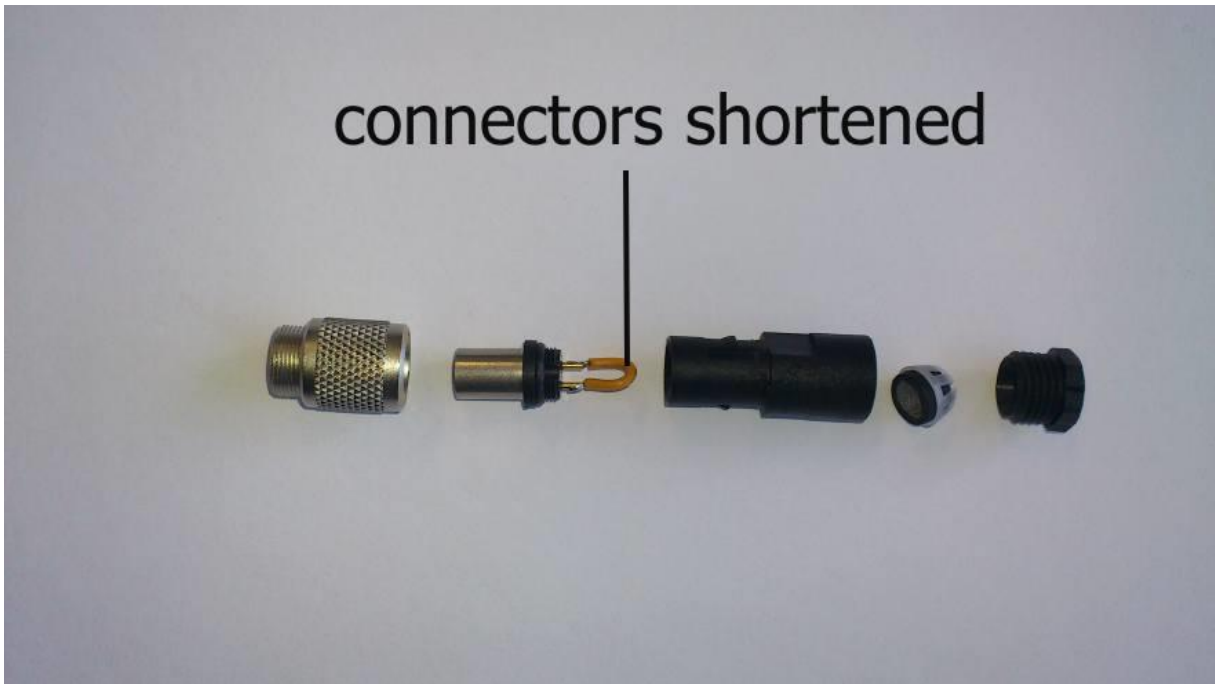

 Z-LASER Optoelektronik GmbH Merzhauser Str. 134 D-79100 Freiburg Tel.: (0761)29644-44 Fax: (0761)29644-55/56	Product <b>Z****Q2-F-808-lp**</b>	Date: <b>2016.04.21</b>	Page: <b>23 of 52</b>
	Advanced Information <b>Document-ID: UI-ZL-100005-Rev0.3.10-2016-04-21</b>		Author: <b>ST</b>

## 6 Operation

### 6.1 Laser Operation checklist

- Interlock has to be shortened, external power supply to interlock is strictly forbidden!
- Keyswitch has to be plugged in
- Connect power plug to the system (24V, min. 3A)
- Allow system thermal stabilization (proper heat sink required!)
- Ensure all laser safety precautions are taken
- Open shutter

For the different operation forms see the appropriate chapters:

- For use of Graphical User Interface see chapter 0
- For use without modulation / GUI see
- External modulation
  - o TTL (chapter 6.6.1)
  - o SPS (chapter 6.6.2)
- Pattern generator (not yet functional)

### 6.2 Auto-start

When the laser is shipped the native settings for external modulation are:

- emitting with maximum Power
- ready for 5V not inverted TTL modulation

### 6.3 Laser Warm-up and Standby

Warm-up time is around 30 seconds, depending on the ambient temperature.



 Z-LASER Optoelektronik GmbH Merzhauser Str. 134 D-79100 Freiburg Tel.: (0761)29644-44 Fax: (0761)29644-55/56	Product <b>Z***Q2-F-808-1p**</b>	Date: <b>2016.04.21</b>	Page: <b>24 of 52</b>
	Advanced Information <b>Document-ID: UI-ZL-100005-Rev0.3.10-2016-04-21</b>		Author: <b>ST</b>

## 6.4 Shutter Operation

To open the shutter move the shutter handle, placed at the front side beside the laser aperture away from the aperture until the mechanical limit is reached.

To close the shutter push the shutter handle towards the laser aperture until no further movement is possible.

No excessive force is necessary!

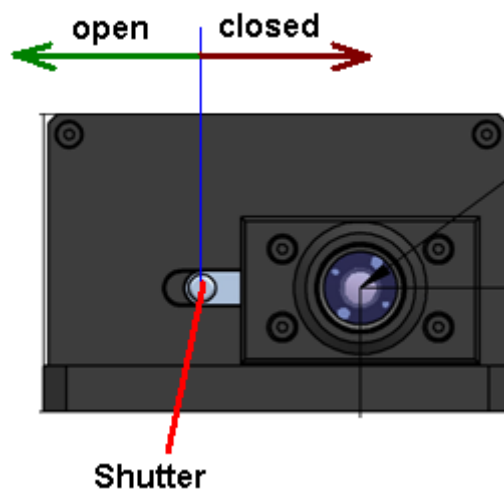

Front view of laser

## 6.5 No modulation operation

If you do not want to modulate the laser signal and the use of a computer is not possible or wished, you can start the laser in continues wave mode at the highest possible output power with the following steps:

- 1.) Supply the laser with power (+24V).
- 2.) Interlock hast to be shortened.
- 3.) Keyswitch has to be inserted.
- 4.) Set 5V to pin 4 "SYS enable" at the laser control connector.
- 5.) Set 5V to pin 7 "Laser on" at the laser control connector.

The laser is now emitting at highest possible power → be careful!

- 6.) Open the shutter.

If you want to change the output power see chapter 0 GUI.



 Z-LASER Optoelektronik GmbH Merzhauser Str. 134 D-79100 Freiburg Tel.: (0761)29644-44 Fax: (0761)29644-55/56	Product <b>Z****Q2-F-808-1p**</b>	Date: <b>2016.04.21</b>	Page: <b>25 of 52</b>
	Advanced Information <b>Document-ID: UI-ZL-100005-Rev0.3.10-2016-04-21</b>		Author: <b>ST</b>

## 6.6 Modulation

### 6.6.1 Digital TTL-Modulation

5V = logic 1

0V = logic 0

To use the non-inverted digital TTL-Modulation follow the upcoming steps:

- 1.) Supply the laser with power (24V), interlock has to be shortened and keyswitch inserted.
- 2.) Put 5V to pin 4 "sys enabled", ground is pin 9 "GND I/O"
- 3.) Put the TTL-signal to pin 7 "laser on", ground is pin 9 "GND I/O"
- 4.) Optional: if you want to use an inverted TTL-signal see chapter 6.6.3 to make the necessary changes to the system (you need the GUI for this one time).

On pin 6 "fail out" you can read out the errors in TTL-format.

### 6.6.2 Digital SPS-Modulation

24V = logic 1

0V = logic 0

To use non-inverted SPS-Modulation follow the next steps:

- 1.) Supply the laser with power (24V), the interlock has to be shortened and the keyswitch has to be inserted.

The following steps have to be done only one time to set the laser to SPS modulation, the values you set there are saved to the internal memory.

- 2.) Connect laser via RS232 to a computer, where you have installed and started the software of the ZQ-2.
- 3.) Select the correct serial port (com port) that is connected with the ZQ2.
- 4.) Flag the check-box "activate laser control".
- 5.) Move the lever from "TTL Level (5V)" to "SPS Level 24V".
- 6.) Optional: set the laser power to the level you want.
- 7.) Optional: for inverted TTL-signals move the lever to "inverted signal".
- 8.) De-flag the check-box "activate laser control" and quit the program with the "quit" button. Disconnect the RS232. All settings are now saved to the internal memory of the laser. The laser will use the set settings at the next start-up.

The following steps assume that you have followed step 2 to 8 once, with a resulting not inverted SPS signal setting

 Z-LASER Optoelektronik GmbH Merzhauser Str. 134 D-79100 Freiburg Tel.: (0761)29644-44 Fax: (0761)29644-55/56	Product <b>Z****Q2-F-808-1p**</b>	Date: <b>2016.04.21</b>	Page: <b>26 of 52</b>
	Advanced Information <b>Document-ID: UI-ZL-100005-Rev0.3.10-2016-04-21</b>		Author: <b>ST</b>

- 9.) Put 24V to the “sys enable”-pin (pin 4) (ground is pin 9)
- 10.) Put your SPS-signal to the “laser on” (pin 7) (ground is pin 9)

Default logic level at Pin-6 is +5V (TTL). To read out errors at pin 6 “fail out” as a SPS-signal you have to put 24V to pin 1 “VCC I/O” additionally.

### 6.6.3 Use of inverted signals

To switch to inverted signals at SPS or TTL modulation connect the laser to a computer and use the Graphical User Interface.

In the GUI do as described (proper working connection is assumed):

- 1.) flag the check-box “activate laser control”,
- 2.) move the lever from “not inverted signal” to “inverted signal”
- 3.) De-flag the check-box “activate laser control” and quit the program with the “quit” button. Disconnect the RS232. All settings are now saved to the internal memory of the laser, even if switched of the laser will use the set settings at next start-up.)

### 6.6.4 Pattern generator

On demand.

 Z-LASER Optoelektronik GmbH Merzhauser Str. 134 D-79100 Freiburg Tel.: (0761)29644-44 Fax: (0761)29644-55/56	Product <b>Z****Q2-F-808-Ip**</b>	Date: <b>2016.04.21</b>	Page: <b>27 of 52</b>
	Advanced Information <b>Document-ID: UI-ZL-100005-Rev0.3.10-2016-04-21</b>		Author: <b>ST</b>

## 6.7 LED flashing signals

Status	Laser (Yellow)	Status (red)	Ready (green)
Power Up	running light	running light	running light
Shutter Closed	on (Laser on) off (Laser off)	off	blinking (2 Hz)
Running	on (Laser on) off (Laser off)	off	on
<b>Warnings:</b>			
Critical Temperature Of Laser Diode	on (Laser on) off (Laser off)	on	2 blinks
Critical Temperature Of Base Plate	on (Laser on) off (Laser off)	on	3 blinks
Critical Temperature Of Laser Driver	on (Laser on) off (Laser off)	on	4 blinks
Laser Diode Reached End Of Life	on (Laser on) off (Laser off)	on	6 blinks
Laser Control Activated	on (Laser on) off (Laser off)	on	7 blinks
Problem In Internal Communication	on (Laser on) off (Laser off)	on	8 blinks
<b>Errors:</b>			
Temperature Of Laser Diode Is Too High/Low	off	blinking (2 Hz)	2 blinks
Temperature Of Base Plate Is Too High/Low	off	blinking (2 Hz)	3 blinks
Temperature Of Laser Driver Is Too High/Low	off	blinking (2 Hz)	4 blinks
Hardware Error	off	blinking (2 Hz)	5 blinks
Missing Keyswitch	off	blinking (2 Hz)	6 blinks
Open Interlock	Off	blinking (2 Hz)	7 blinks
Wrong Input Voltage	off	blinking (2 Hz)	8 blinks
Missing System Enable	off	blinking (2 Hz)	9 blinks
Warming Up	off	blinking (10Hz)	blinking (10Hz)

 Z-LASER Optoelektronik GmbH Merzhauser Str. 134 D-79100 Freiburg Tel.: (0761)29644-44 Fax: (0761)29644-55/56	Product <b>Z****Q2-F-808-lp**</b>	Date: <b>2016.04.21</b>	Page: <b>28 of 52</b>
	Advanced Information <b>Document-ID: UI-ZL-100005-Rev0.3.10-2016-04-21</b>	Author: <b>ST</b>	

## 7 Remote operation

### 7.1 RS-232 Connection and Setup

- Data bits: 8
- Stop Bits: 1
- Parity: None
- Baud rate: 9,6 kBd
- Data flow control: None

### 7.2 Command and Query Summary

For the communication with the ZQ-2 the syntax of SCPI standard is used. Conformity to the SCPI specifications is not guaranteed.

### 7.3 Command Details

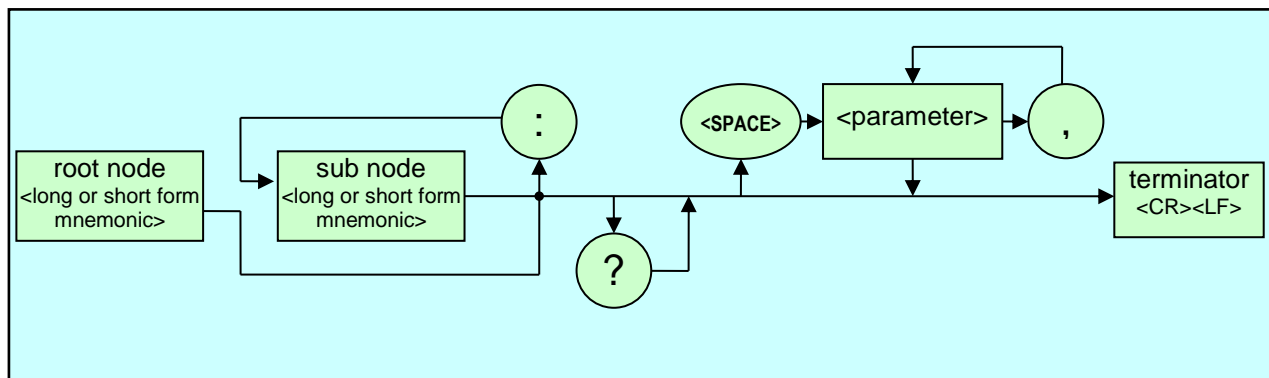

### 7.4 Commands

Each command has a long form and an abbreviated short form. The syntax used in this table use uppercase characters to identify the short form of a particular keyword. The remainder of the keyword is lower case to complete the long form.

Root Node	Sub Node 1	Sub Node 2	Sub Node 3	Read / Write	Parameter			Example
					call arguments	Response	Description	
<b>DIAG</b> nostic								
	ERRor?	-	-	R	-	<R1>	<R1>: <ASCII string>	
	WARNing?	-	-	R	-	<R1>	<R1>: <ASCII string>	

 Z-LASER Optoelektronik GmbH Merzhauser Str. 134 D-79100 Freiburg Tel.: (0761)29644-44 Fax: (0761)29644-55/56	Product <b>Z****Q2-F-808-lp**</b>	Date: <b>2016.04.21</b>	Page: <b>29 of 52</b>
	Advanced Information <b>Document-ID: UI-ZL-100005-Rev0.3.10-2016-04-21</b>		Author: <b>ST</b>

Root Node	Sub Node 1	Sub Node 2	Sub Node 3	Read / Write	Parameter			Example
					call arguments	Response	Description	
	STATus?	-	-	R	-	<R1>	<R1>: <ASCII string>	
<b>LASer</b>								
	LASer?	-	-	R	-	<R1>	<R1>: ON;OFF	LASer?<crLf> →ON<cr><lf>
	LASer	-	-	W	<C1>	-	<C1>: ON;OFF;ENABLE;DISABLE	LASer ON<crLf> →OK<crLf>
	POWer?	-	-	R	-	<R1>	<R1>: ON,OFF	
	POWer	-	-	W	<C1>	-	<C1>: 0...MaxPower [mW]	LASer POWer 1000 <crLf> →OK <cr> <lf>
<b>MODulation</b>								
		EXTErn?	-	R	-	<R1>	<R1>: ON;OFF	
		EXTErn	-	W	<C1>	-	<C1>: ON;OFF	
<b>SYStem</b>								
	CONFIg?	-	-	R	-	<R1>,<R2>,<R3>	<R1>: <wavelength> <wavelength>: /TBD/.../TBD/ [nm] <R2>: <power> <power>: /TBD/.../TBD/ [mW] <R3>: <hardware> <hardware>: Bit0: NTC1-TEC Bit1: NTC2-TEC Bit2: NTC3-TEC Bit3: NTC-HS (Humidity Sensor) Bit4: NTC1-LD Bit5: NTC2-LD Bit6: MD1 (Monitor Diode 1) Bit7: MD2 (Monitor Diode 2) Bit8,Bit9: 00 (1xTEC),10 (2xTEC),01 (3xTEC), 11 (4xTEC) Bit10: reserved (future) Bit11: reserved (future) Bit12: APC-Mode Bit13: VDrv-Select Bit14: Faserkopplung Bit15: reserved (future)	SYS:CONF?<crLf> → 1000,635,0x8011<crLf> >
	SERial?	-	-	R	-	<R1>	<R1>: <sn> <sn>: ASCII[10]	SYS:SER?<crLf> → S123456789<crLf>
<b>SIGnal</b>								
		LEVEl?	-	R	-	<R1>	<R1>: TTL;24V	
		LEVEl	-	W	<C1>	-	<C1>: TTL;24V	
		INVErt?	-	R	-	<R1>	<R1>: ON;OFF	
		INVErt	-	W	<C1>	-	<C1>: ON;OFF	
<b>TIME</b>								
	VERsion?	-	-	R	<R1>	-	<R1>: <maj>.<med>.<min> <maj>: 0...255 <med>: 0...255 <min>: 0...255	SYS:VERS?<crLf> → 1.1.2<crLf>
<b>TEMPerature</b>								
	TEMPerature	-	-	R	<C1>	<R1>	<C1>:	

 Z-LASER Optoelektronik GmbH Merzhauser Str. 134 D-79100 Freiburg Tel.: (0761)29644-44 Fax: (0761)29644-55/56	Product <b>Z****Q2-F-808-Ip**</b>	Date: <b>2016.04.21</b>	Page: <b>30 of 52</b>
	Advanced Information <b>Document-ID: UI-ZL-100005-Rev0.3.10-2016-04-21</b>		Author: <b>ST</b>

Root Node	Sub Node 1	Sub Node 2	Sub Node 3	Read / Write	Parameter			Example
					call arguments	Response	Description	
?							LASER;BASE1;BASE2;DRIVER ; ENVIRONMENT <R1>: -128.00...127.00	
	<b>LASer</b>							
		ALarm?	-	R	-	<R1><R2 >	<R1,R2>: -128...127 [°C] R1 = Lower Limit; R2 = Upper Limit	
		WARning?	-	R	-	<R1><R2 >	<R1,R2>: -128...127 [°C] R1 = Lower Limit; R2 = Upper Limit	
		MIN?	-	R	-	<R1>	<R1>: -128...127 [°C]	
		MAX?	-	R	-	<R1>	<R1>: -128...127 [°C]	
	<b>BASE1</b>	→	→	→	→	→	→	Same as TEMPerature:LASer
	<b>BASE2</b>	→	→	→	→	→	→	Same as TEMPerature:LASer
	<b>DRIVER</b>	→	→	→	→	→	→	Same as TEMPerature:LASer
	<b>ENVironment</b>	→	→	→	→	→	→	Same as TEMPerature:LASer

Abbr.	Meaning
<crLf>	HEX: 0x0D 0x0A ASCII: Carriage Return Line Feed
R	Read
W	Write
RW	Read/Write
CAL	Accepted in Calibration Mode only
WPC	Write Protected (Cal.-Mode)
WPU	Write Protection (User Mode)
RPC	Read Protected (Cal.-Mode)
RPU	Read Protection (User Mode)
Cn	Call Parameter (n: 1...2)
Rn	Response Parameter (n: 1...2)

#### 7.4.1 Example Commands

Switch Laser On:

LASER ON <crLf>    Answer: OK or Command Error:-224 (if Laser is already ON)

Switch Laser On (short form):

LAS ON <crLf>    Answer: OK or Command Error:-224 (if Laser is already ON)

 Z-LASER Optoelektronik GmbH Merzhauser Str. 134 D-79100 Freiburg Tel.: (0761)29644-44 Fax: (0761)29644-55/56	Product <b>Z****Q2-F-808-lp**</b>	Date: <b>2016.04.21</b>	Page: <b>31 of 52</b>
	Advanced Information <b>Document-ID: UI-ZL-100005-Rev0.3.10-2016-04-21</b>		Author: <b>ST</b>

**Switch Laser Off:**

LASER OFF <crLf> Answer: OK or Command Error:-224 (if Laser is already OFF)

**Read Output Power (short form):**

LAS:POWER? <crLf> Answer: e.g. 5000 (Output Power in mW)

**Set Output Power to 3W:**

LASER:POWER 3000 <crLf> Answer: OK

**Read current temperature of laser diode (short form):**

TEMP? LASER <crLf> Answer: e.g. 25.00 (Temperature of laser diode = 25.00°C)

 Z-LASER Optoelektronik GmbH Merzhauser Str. 134 D-79100 Freiburg Tel.: (0761)29644-44 Fax: (0761)29644-55/56	Product <b>Z****Q2-F-808-lp**</b>	Date: <b>2016.04.21</b>	Page: <b>32 of 52</b>
	Advanced Information <b>Document-ID: UI-ZL-100005-Rev0.3.10-2016-04-21</b>		Author: <b>ST</b>

## 8 Operation via GUI

### 8.1 Supported Operating Systems

Windows 2000/ Windows XP / Windows Vista / Windows 7

### 8.2 USB-Stick Contents

- ZQ2-Control Setup
  - ZQ2-Control
  - NI LabVIEW Run-Time Engine 2009
  - NI-VISA Runtime 4.5

### 8.3 Installation of ZQ2 Control

To install the ZQ2 software package start the ZQ2 setup located at:

\ZQ2\_CONTROL\ZQ2\_Installer\Volume\setup.exe

This setup installs the following components (if not available) on your PC:

- ZQ2-Control
- NI LabVIEW Run-Time Engine 2009
- NI-VISA Runtime 4.5

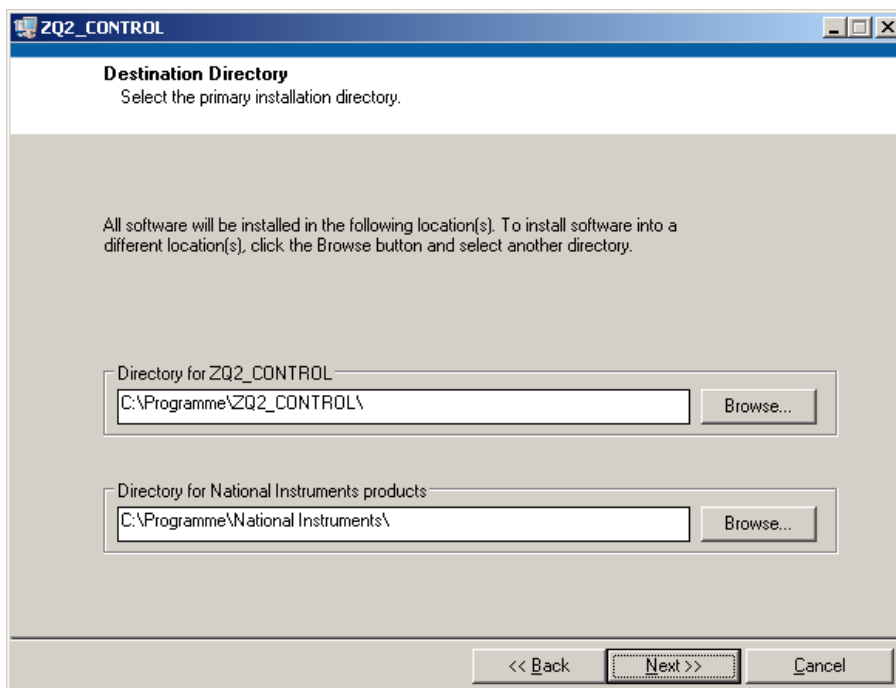

**8-1 Setup Dialog: Destination Directory**



 Z-LASER Optoelektronik GmbH Merzhauser Str. 134 D-79100 Freiburg Tel.: (0761)29644-44 Fax: (0761)29644-55/56	Product <b>Z****Q2-F-808-1p**</b>	Date: <b>2016.04.21</b>	Page: <b>33 of 52</b>
	Advanced Information <b>Document-ID: UI-ZL-100005-Rev0.3.10-2016-04-21</b>		Author: <b>ST</b>

Choose your installation folders. One directory is for ZQ2 Control Software and another one for National Instrument Runtime Engines. Click on „Next“.

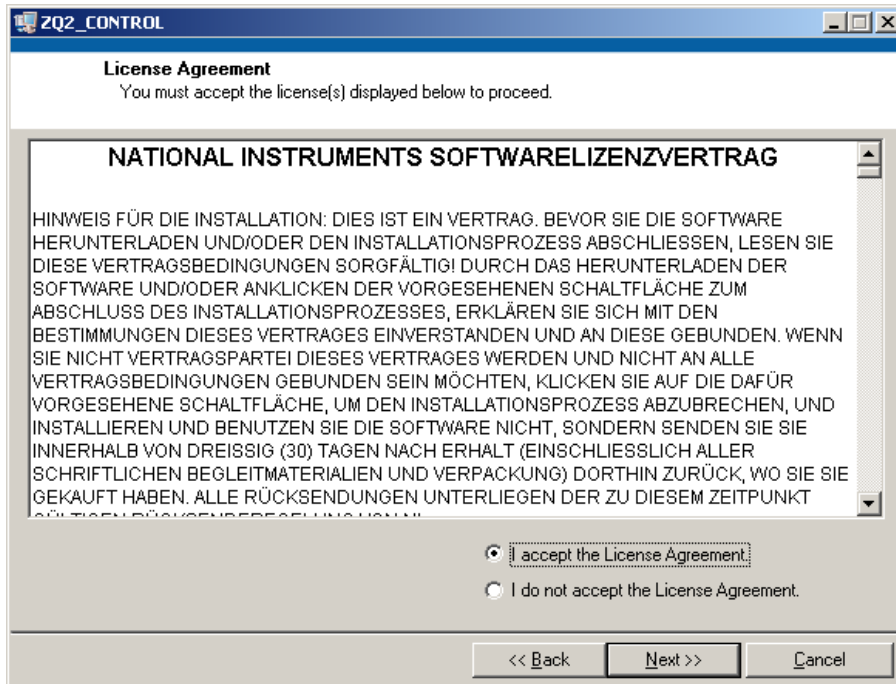

## 8-2 Setup Dialog: License Agreement

Choose „I accept the License Agreement“ to proceed. Click on „Next“.

 Z-LASER Optoelektronik GmbH Merzhauser Str. 134 D-79100 Freiburg Tel.: (0761)29644-44 Fax: (0761)29644-55/56	Product <b>Z****Q2-F-808-1p**</b>	Date: <b>2016.04.21</b>	Page: <b>34 of 52</b>
	Advanced Information <b>Document-ID: UI-ZL-100005-Rev0.3.10-2016-04-21</b>		Author: <b>ST</b>

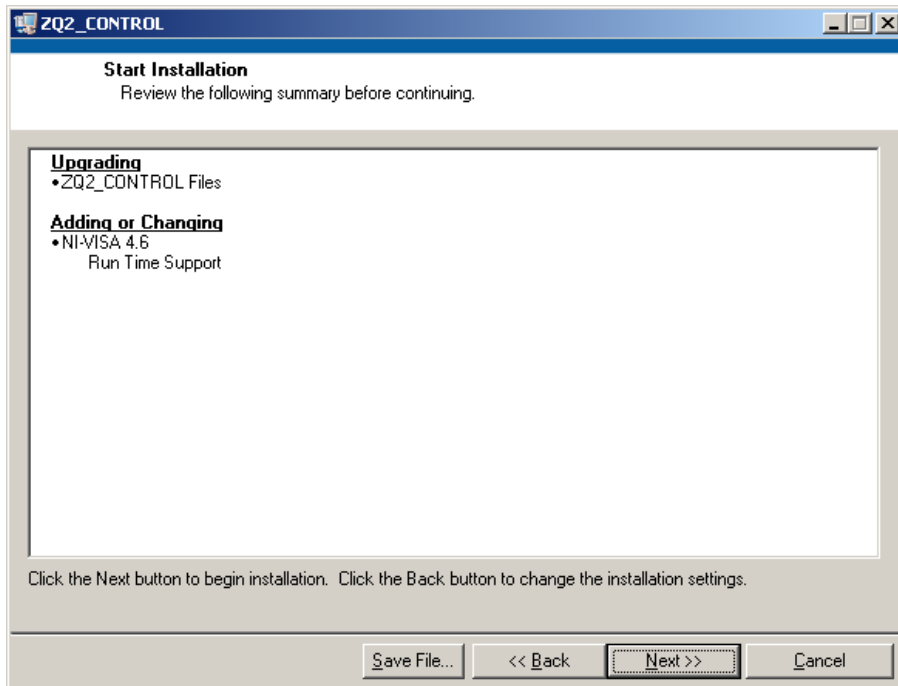

### 8-3 Setup Dialog: Start Installation

A summary of the installation is displayed. Click „Next“ to begin installation.

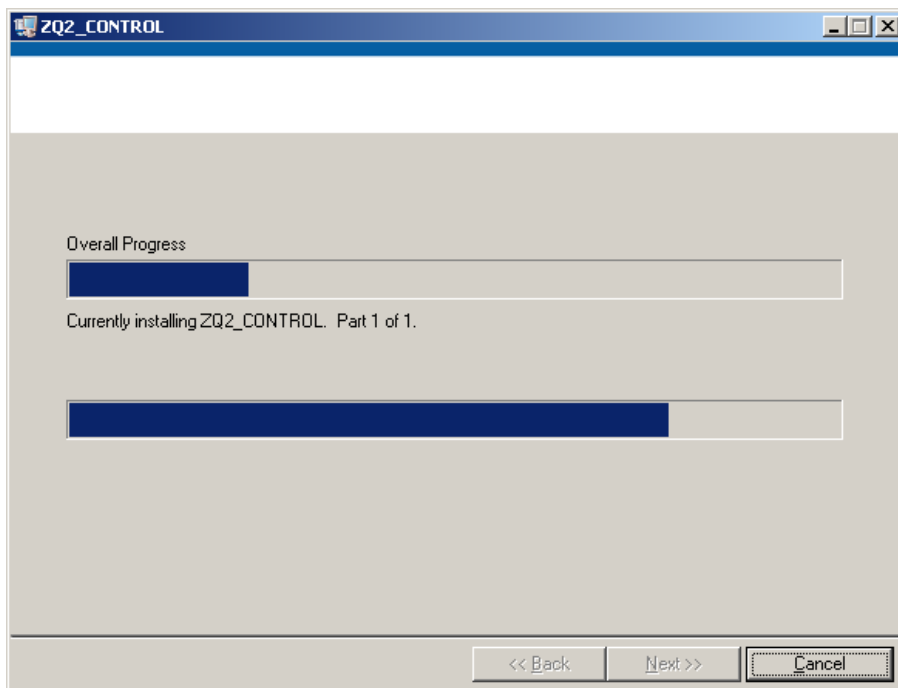

### 8-4 Setup Dialog: Installation Status

The installation process can take several minutes.

 Z-LASER Optoelektronik GmbH Merzhauser Str. 134 D-79100 Freiburg Tel.: (0761)29644-44 Fax: (0761)29644-55/56	Product <b>Z****Q2-F-808-1p**</b>	Date: <b>2016.04.21</b>	Page: <b>35 of 52</b>
	Advanced Information <b>Document-ID: UI-ZL-100005-Rev0.3.10-2016-04-21</b>		Author: <b>ST</b>

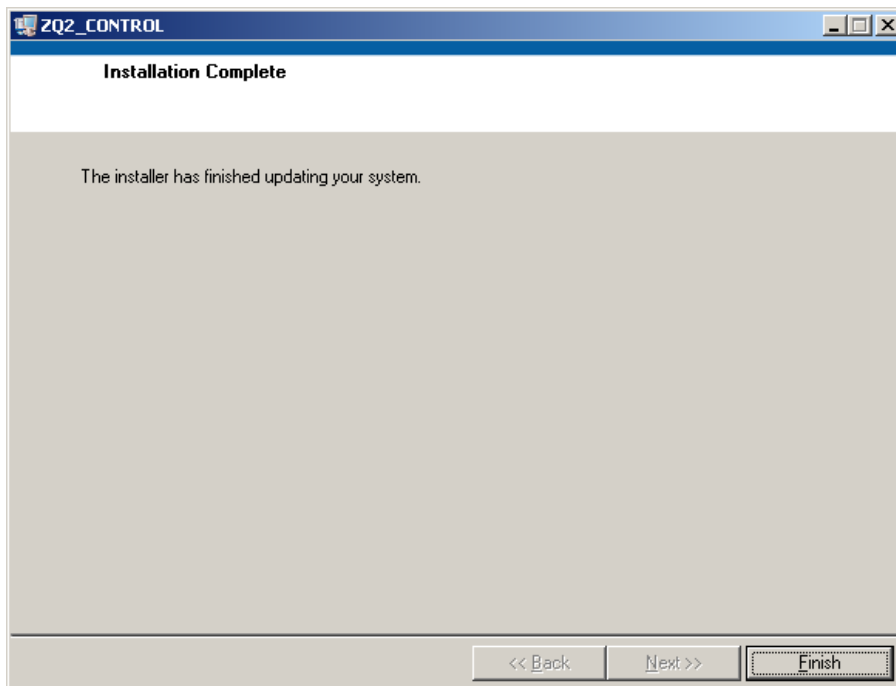

#### 8-5 Setup Dialog: Installation Complete

Click „Finish“ to complete ZQ2-Control installation process.

## 8.4 Exploring ZQ2 Control

### 8.4.1 First Steps

- 1) Connect ZQ2 with a serial cable (“RS-232” connector at backside of ZQ2) to your PC
- 2) Power up ZQ2
- 3) Start ZQ2 control software
- 4) Select the serial port (COM port) that is connected with ZQ2

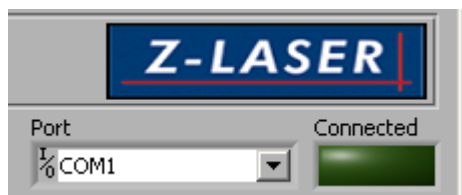

- 5) The “Connected” indicator turns yellow if a ZQ2 is connected at the selected port.
- 6) Check Error Box for pending errors:

 Z-LASER Optoelektronik GmbH Merzhauser Str. 134 D-79100 Freiburg Tel.: (0761)29644-44 Fax: (0761)29644-55/56	Product <b>Z****Q2-F-808-lp**</b>	Date: <b>2016.04.21</b>	Page: <b>36 of 52</b>
	Advanced Information <b>Document-ID: UI-ZL-100005-Rev0.3.10-2016-04-21</b>		Author: <b>ST</b>

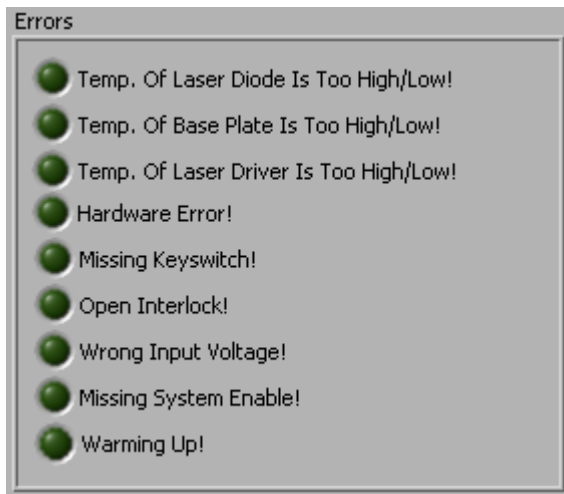

Resolve all pending errors (e.g. insert Keyswitch or close Interlock circuit).  
**If you want to control the laser with ZQ2-Control Software you can ignore “Missing System Enable” error.**

- 7) Set output power control knob to desired optical output power:

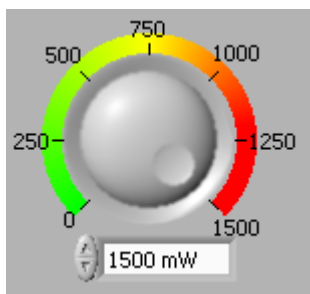

- 8) Tick “Activate Laser Control” to be able to switch the laser emission on/off with ZQ2 control. If “Laser Control” is activated, modulation signals at “Laser Control” connector of ZQ2 are ignored.

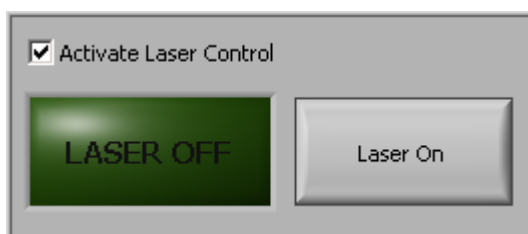

- 9) Press “Laser On” button to switch on laser emission.

 Z-LASER Optoelektronik GmbH Merzhauser Str. 134 D-79100 Freiburg Tel.: (0761)29644-44 Fax: (0761)29644-55/56	Product <b>Z****Q2-F-808-1p**</b>	Date: <b>2016.04.21</b>	Page: <b>37 of 52</b>
	Advanced Information <b>Document-ID: UI-ZL-100005-Rev0.3.10-2016-04-21</b>		Author: <b>ST</b>

## 8.4.2 Home Screen

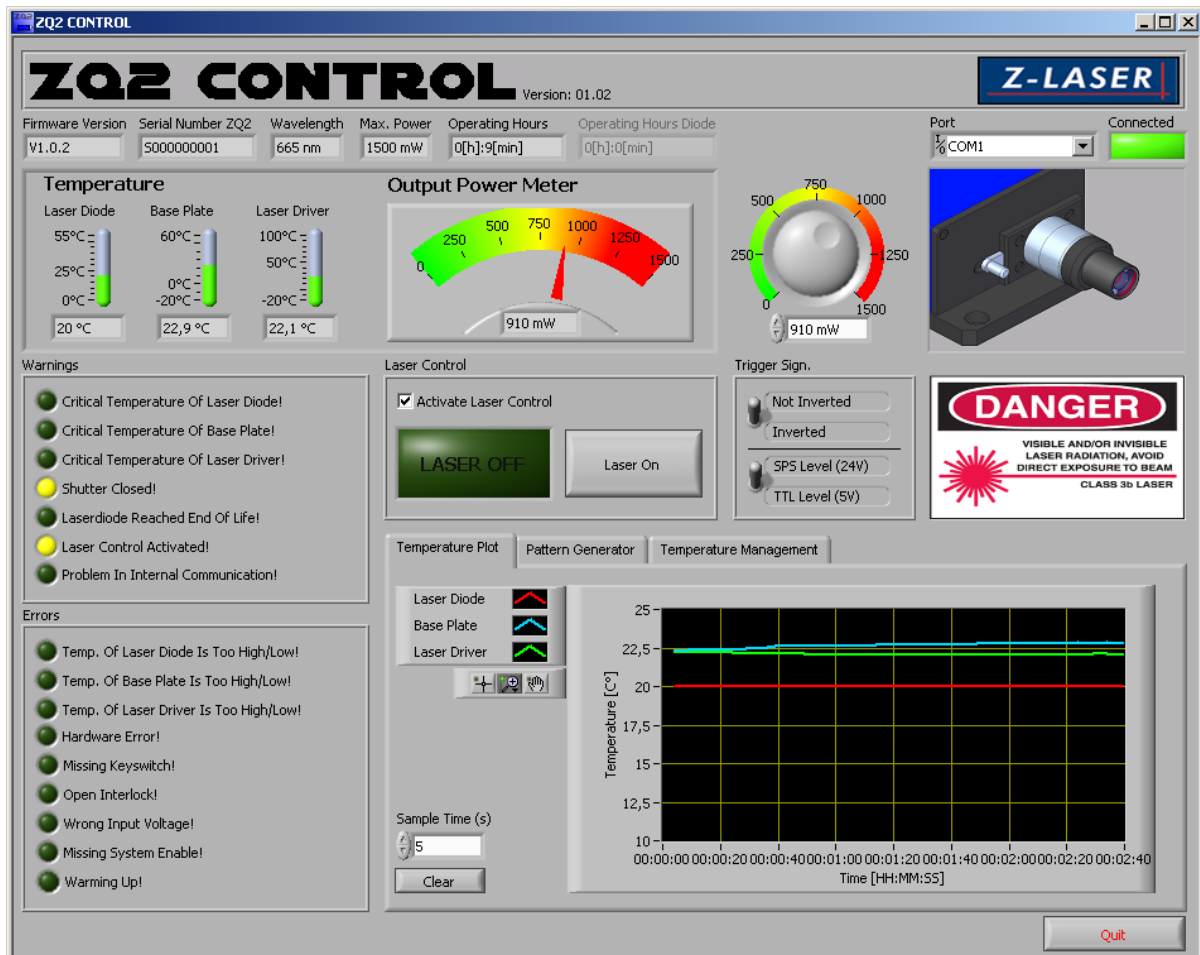

8-6 Home screen ZQ2 Control

Firmware Version	Serial Number ZQ2	Wavelength	Max. Power	Operating Hours
V1.0.2	5000000001	665 nm	1500 mW	1[h]:7[min]

### 8-7 Hardware Configuration indicators

#### 8.4.2.1 "Firmware Version" indicator field

This indicator field displays current firmware version of connected ZQ2.

#### 8.4.2.2 "Serial Number ZQ2" indicator field

This indicator field displays the serial number of connected ZQ2.

 Z-LASER Optoelektronik GmbH Merzhauser Str. 134 D-79100 Freiburg Tel.: (0761)29644-44 Fax: (0761)29644-55/56	Product <b>Z****Q2-F-808-1p**</b>	Date: <b>2016.04.21</b>	Page: <b>38 of 52</b>
	Advanced Information <b>Document-ID: UI-ZL-100005-Rev0.3.10-2016-04-21</b>		Author: <b>ST</b>

#### 8.4.2.3 “Wavelength” indicator field

This indicator field displays the laser wavelength of connected ZQ2.

#### 8.4.2.4 “Max. Power” indicator field

This indicator field displays the maximum optical output power of connected ZQ2.

#### 8.4.2.5 “Operating Hours” indicator field

This indicator field displays operating hours (powered electronic) of connected ZQ2.

#### 8.4.2.6 “Operating Hours Diode” indicator field

This indicator field displays the operating hours of the laser diode of connected ZQ2.

**-Not yet implemented-**



#### 8-8: Serial Port Selection

##### 8.4.2.7 “Port” select box

Use this select box to select serial port connected with ZQ2.

##### 8.4.2.8 “Connected” indicator

Changes to yellow if a ZQ2 is connected at selected port.

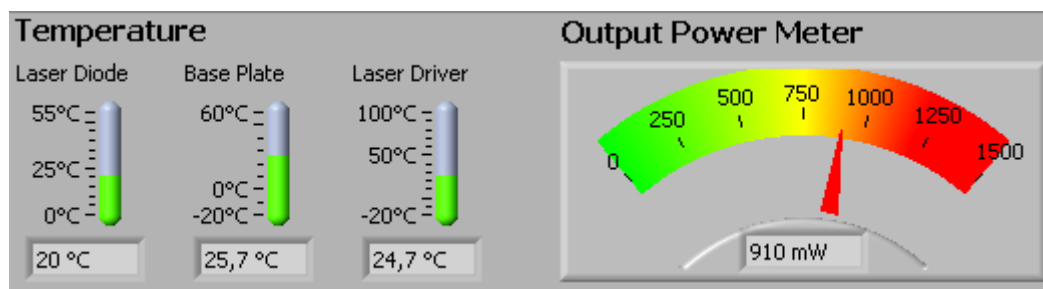

#### 8-9 Temperature and Power Meter

##### 8.4.2.9 “Laser Diode” Thermometer

This thermometer indicates current laser diode temperature of connected ZQ2 in °C. A green filling signalizes that the temperature is Ok. A red filling indicates that the temperature is critical but the laser is still working. If the temperature reaches the minimum or maximum of the temperature scale the laser is switched of and a temperature error is displayed.

 Z-LASER Optoelektronik GmbH Merzhauser Str. 134 D-79100 Freiburg Tel.: (0761)29644-44 Fax: (0761)29644-55/56	Product <b>Z****Q2-F-808-1p**</b>	Date: <b>2016.04.21</b>	Page: <b>39 of 52</b>
	Advanced Information <b>Document-ID: UI-ZL-100005-Rev0.3.10-2016-04-21</b>		Author: <b>ST</b>

#### 8.4.2.10 “Base Plate” thermometer

This thermometer indicates current base plate (housing) temperature of connected ZQ2 in °C. A green filling signalizes that the temperature is Ok. A red filling indicates that the temperature is critical but the laser is still working. If the temperature reaches the minimum or maximum of the temperature scale the laser is switched of and a temperature error is displayed.

#### 8.4.2.11 “Laser Driver” thermometer

This thermometer indicates current laser driver (PCB) temperature of connected ZQ2 in °C. A green filling signalizes that the temperature is Ok. A red filling indicates that the temperature is critical but the laser is still working. If the temperature reaches the minimum or maximum of the temperature scale the laser is switched of and a temperature error is displayed.

#### 8.4.2.12 “Output Power Meter”

This meter displays the current set output power in mW.

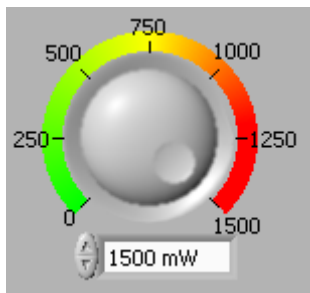

#### 8-10: Optical Output Power Knob

#### 8.4.2.13 Optical Output Power Knob

Use this knob to adjust the optical output power in mW.

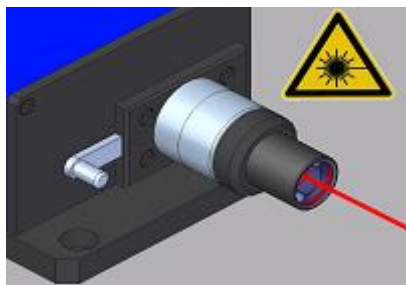

#### 8-11: Shutter Indicator

#### 8.4.2.14 Shutter indicator

This picture displays the current status of mechanical shutter. It is additionally displayed in the “Warnings” Box.

 Z-LASER Optoelektronik GmbH Merzhauser Str. 134 D-79100 Freiburg Tel.: (0761)29644-44 Fax: (0761)29644-55/56	Product <b>Z****Q2-F-808-1p**</b>	Date: <b>2016.04.21</b>	Page: <b>40 of 52</b>
	Advanced Information <b>Document-ID: UI-ZL-100005-Rev0.3.10-2016-04-21</b>		Author: <b>ST</b>

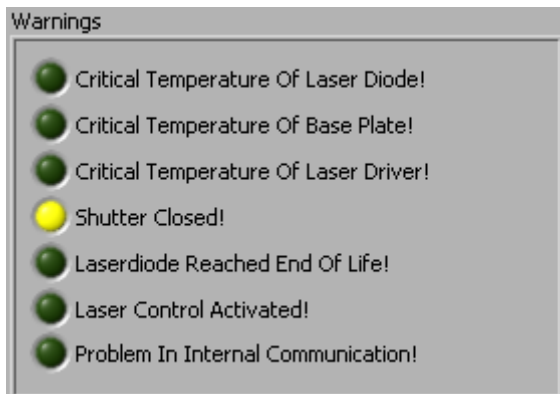

## 8-12: Warning Indicators

### 8.4.2.15 “Warnings” indicator box

Several warning indicators are grouped in this box. A warning doesn't switch off laser emission. It is only information for the user.

- Critical Temperature of Laser Diode: Laser Diode reaches a critical temperature. See corresponding thermometer for possible countermeasures (cooling or heating).
- Critical Temperature of Base Plate: Base Plate reaches a critical temperature. See corresponding thermometer for possible countermeasures (cooling or heating).
- Critical Temperature of Laser Driver: Laser Driver reaches a critical temperature. See corresponding thermometer for possible countermeasures (cooling or heating).
- Shutter Closed: The mechanical Shutter is closed. No laser emission visible.
- Laser Diode Reached End of Life: The laser diode exceeded expected product lifetime.
- Problem In Internal Communication: A corrupted data transmission between two internal devices has been detected.

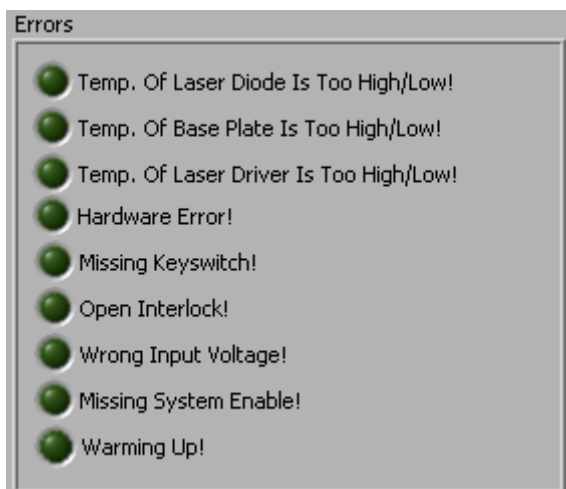

## 8-13: Error Indicators



 Z-LASER Optoelektronik GmbH Merzhauser Str. 134 D-79100 Freiburg Tel.: (0761)29644-44 Fax: (0761)29644-55/56	Product <b>Z****Q2-F-808-1p**</b>	Date: <b>2016.04.21</b>	Page: <b>41 of 52</b>
	Advanced Information <b>Document-ID: UI-ZL-100005-Rev0.3.10-2016-04-21</b>		Author: <b>ST</b>

#### 8.4.2.16 “Errors” indicator box

Several error indicators are grouped in this box. Each error switches off laser emission. After resolving the last pending error the Laser emission can be activated again by:

- Pressing “Laser On” Button again in case of “Laser control activated”
- A rising edge at the “System Enable” input in case of external modulation (laser control deactivated)

The “Missing System Enable” error is ignored in “Laser control activated” mode (LED is switched off).

Error description:

- Temp. Of Laser Diode Is Too High/Low: The laser diode temperature reaches the maximum or minimum temperature allowed. Laser emission is switched off.
- Temp. Of Base Plate Is Too High/Low: The base plate temperature reaches the maximum or minimum temperature allowed. Laser emission is switched off.
- Temp. Of Laser Driver Is Too High/Low: The laser driver temperature reaches the maximum or minimum temperature allowed. Laser emission is switched off.
- Hardware Error: An internal hardware error occurred. This error requires a power up reset. Laser emission is switched off.
- Missing Keyswitch: Keyswitch is missing. Laser emission is switched off.
- Open Interlock: Interlock circuit is open. Laser emission is switched off.
- Wrong Input Voltage: A wrong input voltage was detected. Laser emission is switched off. **Not yet implemented.**
- Missing System Enable: System enable signal is low. Laser emission is switched off (ignored in “Laser control activated” mode).
- Warming Up: **Not yet implemented**

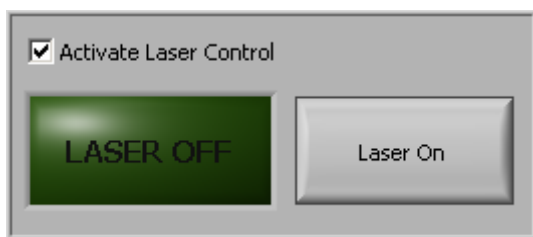

#### 8-14: Laser Control

#### 8.4.2.17 “Activate Laser Control” Tick box

Tick “Activate Laser Control” to control laser emission via ZQ2-Control software. “System Enable” and modulation signals are ignored in this mode.

#### 8.4.2.18 “Laser On/Off” indicator

Indicates current status of laser emission.

 Z-LASER Optoelektronik GmbH Merzhauser Str. 134 D-79100 Freiburg Tel.: (0761)29644-44 Fax: (0761)29644-55/56	Product <b>Z****Q2-F-808-1p**</b>	Date: <b>2016.04.21</b>	Page: <b>42 of 52</b>
	Advanced Information <b>Document-ID: UI-ZL-100005-Rev0.3.10-2016-04-21</b>		Author: <b>ST</b>

#### 8.4.2.19 “Laser On/Off” button

Press button to switch laser emission on/off. To activate Laser On/Off button tick “Activate Laser Control” before.

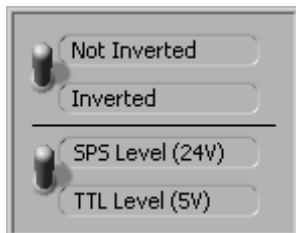

### 8-15: Trigger Signal Configuration

#### 8.4.2.20 “Not Inverted/Inverted” switch

Switch between Inverted or Not Inverted Trigger Signal. The setting is saved in the internal memory of ZQ2 and set as default value when running ZQ2 without ZQ2-Control.

#### 8.4.2.21 “SPS Level (24V)/TTL Level (5V)” switch

Set to “SPS level” in case of 24V trigger signal. Set to “TTL level” in case of 5V trigger signal. The setting is saved in the internal memory of ZQ2 and set as default value when running ZQ2 without ZQ2-Control.

 Z-LASER Optoelektronik GmbH Merzhauser Str. 134 D-79100 Freiburg Tel.: (0761)29644-44 Fax: (0761)29644-55/56	Product <b>Z****Q2-F-808-lp**</b>	Date: <b>2016.04.21</b>	Page: <b>43 of 52</b>
	Advanced Information <b>Document-ID: UI-ZL-100005-Rev0.3.10-2016-04-21</b>		Author: <b>ST</b>

### 8.4.3 Temperature Plot

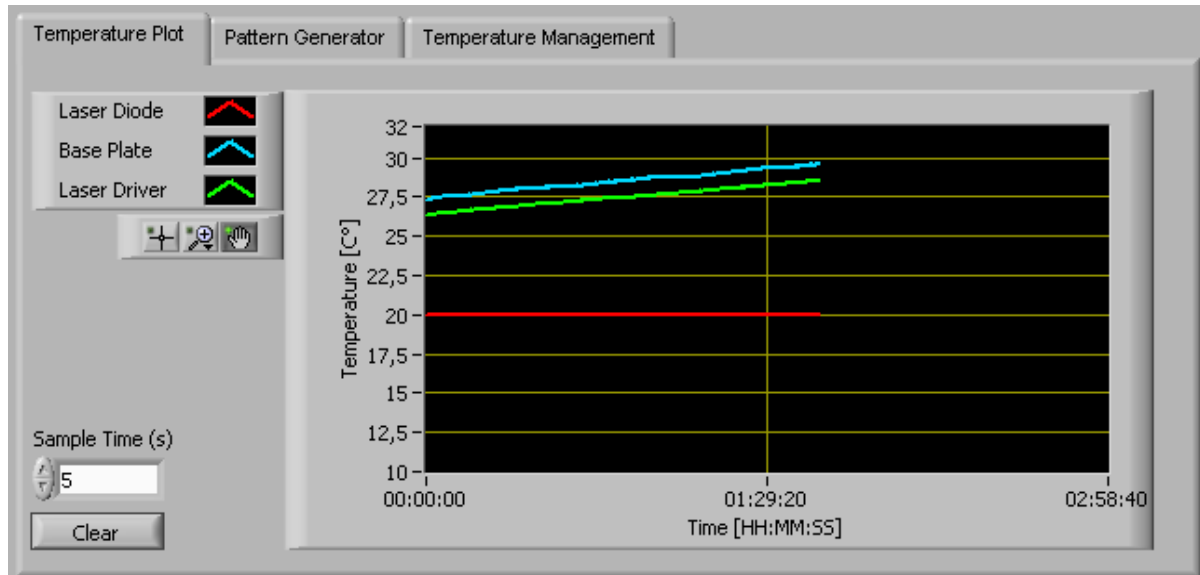

#### 8-16: Temperature Plot

The temperature plot displays all three temperatures over the time.

##### 8.4.3.1 “Sample Time” input field

Set sample time for temperature plot in seconds.

##### 8.4.3.2 “Clear” button

Pressing this button clears the temperature plot.

##### 8.4.3.3 Auto Scaling Time Axis

Right-click on “Time[HH:MM:SS]” opens a context menu for time axis. Tick “Autoscaling X” to activate auto scaling.

### 8.4.4 Pattern Generator

On demand.

 Z-LASER Optoelektronik GmbH Merzhauser Str. 134 D-79100 Freiburg Tel.: (0761)29644-44 Fax: (0761)29644-55/56	Product <b>Z****Q2-F-808-lp**</b>	Date: <b>2016.04.21</b>	Page: <b>44 of 52</b>
	Advanced Information <b>Document-ID: UI-ZL-100005-Rev0.3.10-2016-04-21</b>		Author: <b>ST</b>

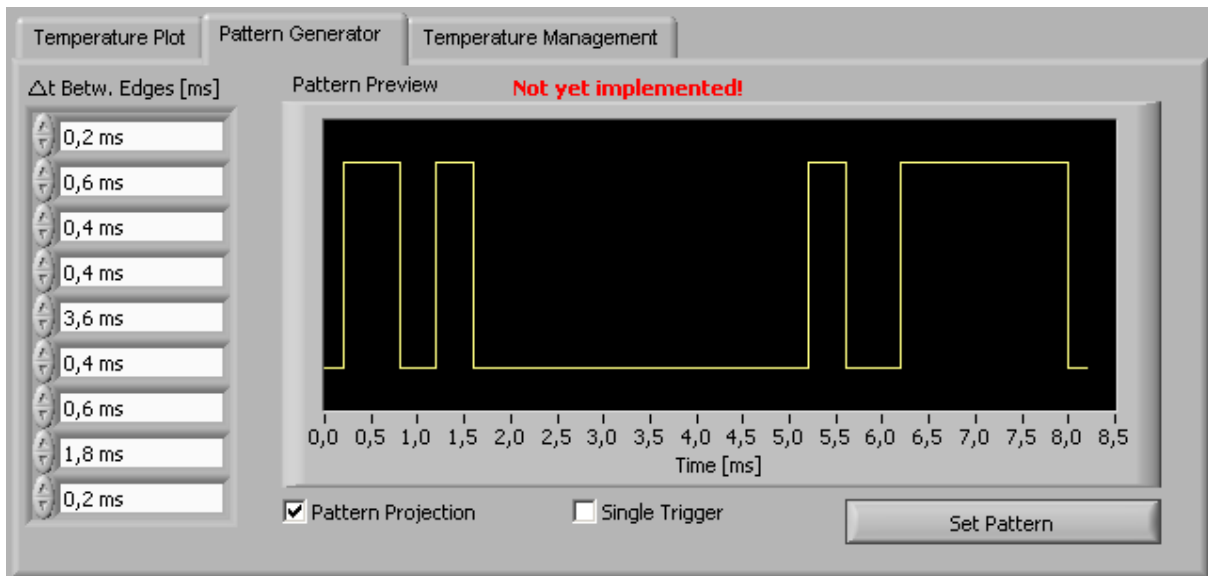

8-17: Pattern Generator

### 8.4.5 Temperature Management

Not yet completely implemented.

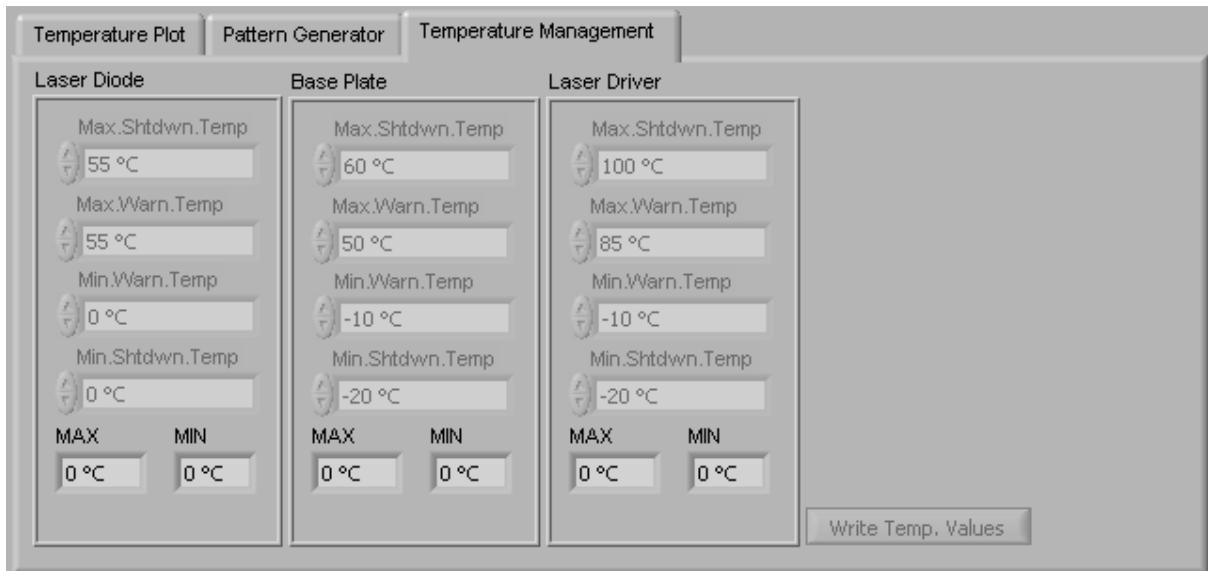

8-18: Temperature Management

#### 8.4.5.1 Laser Diode -> "Max. Shtdwn. Temp." indicator

This indicator displays the maximum shutdown temperature for the laser diode. If this temperature is reached the laser emission is switched off and a temperature error is displayed.

 Z-LASER Optoelektronik GmbH Merzhauser Str. 134 D-79100 Freiburg Tel.: (0761)29644-44 Fax: (0761)29644-55/56	Product <b>Z****Q2-F-808-lp**</b>	Date: <b>2016.04.21</b>	Page: <b>45 of 52</b>
	Advanced Information <b>Document-ID: UI-ZL-100005-Rev0.3.10-2016-04-21</b>		Author: <b>ST</b>

#### 8.4.5.2 Laser Diode -> "Max. Warn. Temp." indicator

This indicator displays the maximum warning temperature for the laser diode. If this temperature is reached a temperature warning is displayed and the laser diode thermometer turns red.

#### 8.4.5.3 Laser Diode -> "Min. Warn. Temp." indicator

This indicator displays the minimum warning temperature for the laser diode. If this temperature is reached a temperature warning is displayed and the laser diode thermometer turns red.

#### 8.4.5.4 Laser Diode -> "Min. Shtdwn. Temp." indicator

This indicator displays the minimum shutdown temperature for the laser diode. If this temperature is reached the laser emission is switched off and a temperature error is displayed.

#### 8.4.5.5 Laser Diode -> "MIN"

This indicator displays the lowest laser diode temperature ever measured during operation.

#### 8.4.5.6 Laser Diode -> "MAX"

This indicator displays the highest laser diode temperature ever measured during operation.

#### 8.4.5.7 Base Plate -> "Max. Shtdwn. Temp." indicator

See chapter 8.4.5.1

#### 8.4.5.8 Base Plate -> "Max. Warn. Temp." indicator

See chapter 8.4.5.2

#### 8.4.5.9 Base Plate -> "Min. Warn. Temp." indicator

See chapter 8.4.5.3.

#### 8.4.5.10 Base Plate -> "Min. Shtdwn. Temp." indicator

See chapter 8.4.5.4

#### 8.4.5.11 Base Plate -> "MIN"

See chapter 8.4.5.5

#### 8.4.5.12 Base Plate -> "MIN"

See chapter 8.4.5.6

 Z-LASER Optoelektronik GmbH Merzhauser Str. 134 D-79100 Freiburg Tel.: (0761)29644-44 Fax: (0761)29644-55/56	Product <b>Z****Q2-F-808-lp**</b>	Date: <b>2016.04.21</b>	Page: <b>46 of 52</b>
	Advanced Information <b>Document-ID: UI-ZL-100005-Rev0.3.10-2016-04-21</b>		Author: <b>ST</b>

8.4.5.13 Laser Driver -> "Max. Shtdwn. Temp." indicator

See chapter 8.4.5.1

8.4.5.14 Laser Driver -> "Max. Warn. Temp." indicator

See chapter 8.4.5.2

8.4.5.15 Laser Driver -> "Min. Warn. Temp." indicator

See chapter 8.4.5.3.

8.4.5.16 Laser Driver -> "Min. Shtdwn. Temp." indicator

See chapter 8.4.5.4

8.4.5.17 Laser Driver -> "MIN"

See chapter 8.4.5.5

8.4.5.18 Laser Driver -> "MIN"

See chapter 8.4.5.6

## 8.4.6 Firmware Update

Since ZQ2 Control Version 1.10 an additional feature was implemented to update the firmware of ZQ2. To update ZQ2 firmware the following steps are required:

1. Connect the ZQ2 with your PC (see chapter 8.4.1)

 Z-LASER Optoelektronik GmbH Merzhauser Str. 134 D-79100 Freiburg Tel.: (0761)29644-44 Fax: (0761)29644-55/56	Product <b>Z****Q2-F-808-lp**</b>	Date: <b>2016.04.21</b>	Page: <b>47 of 52</b>
	Advanced Information <b>Document-ID: UI-ZL-100005-Rev0.3.10-2016-04-21</b>		Author: <b>ST</b>

- Change to FW Update tab and press "Update Firmware" button.

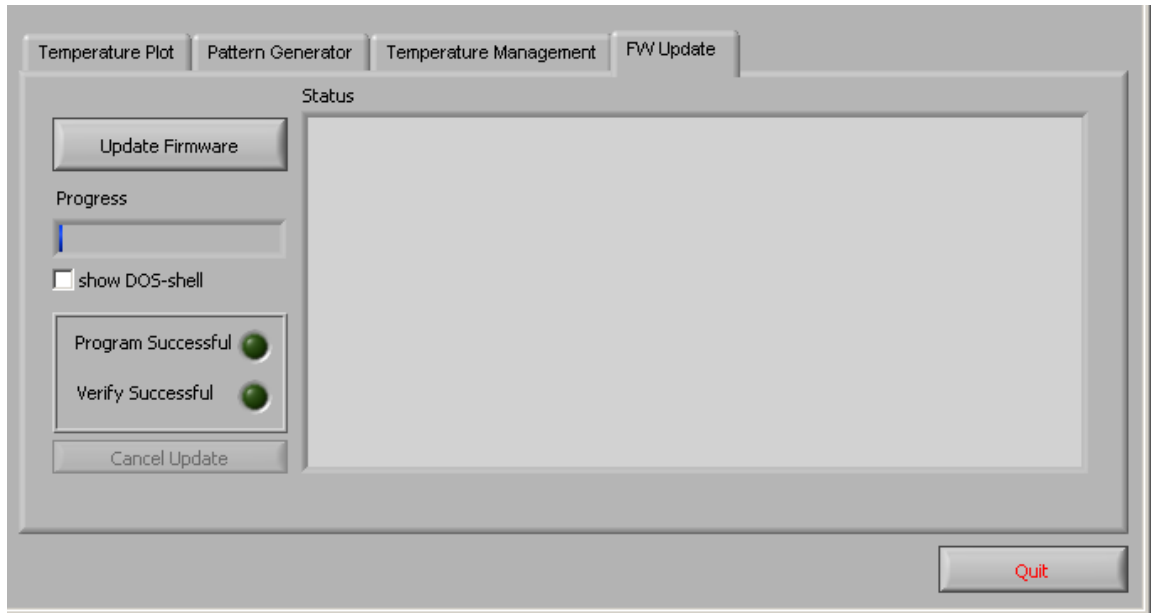

### 8-19 Firmware Update tab

- Select the .hex file containing the software update for ZQ2 and press OK. There are two different PCBs inside ZQ2 that can be updated (Laser-Controller and TEC-Controller). ZQ2-Control checks the .hex file and updates only the corresponding PCB.

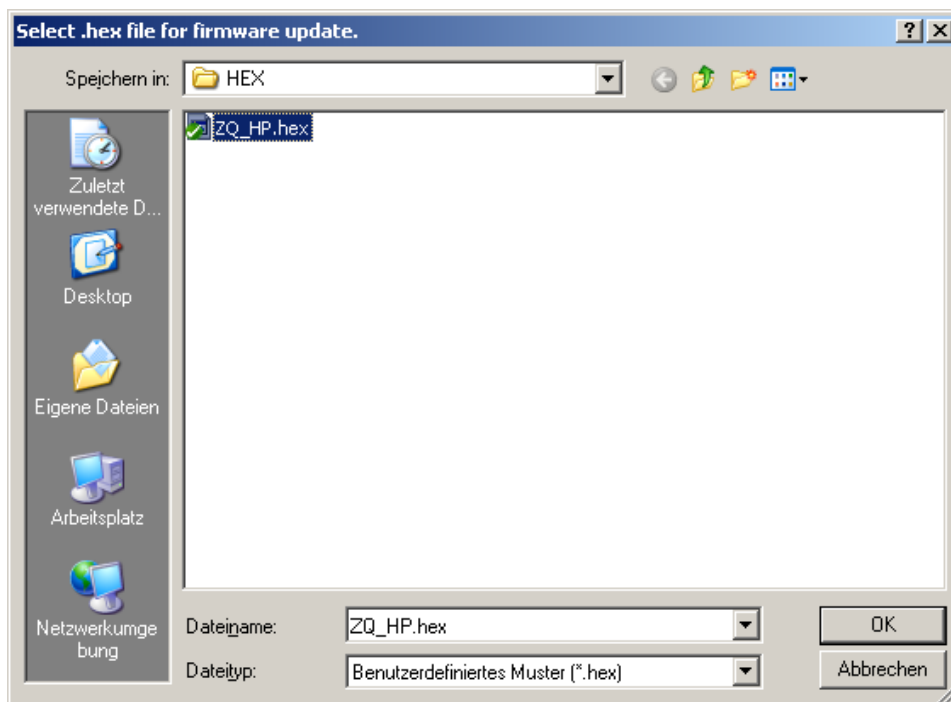

### 8-20 Select .hex file dialog

 Z-LASER Optoelektronik GmbH Merzhauser Str. 134 D-79100 Freiburg Tel.: (0761)29644-44 Fax: (0761)29644-55/56	Product <b>Z****Q2-F-808-lp**</b>	Date: <b>2016.04.21</b>	Page: <b>48 of 52</b>
	Advanced Information <b>Document-ID: UI-ZL-100005-Rev0.3.10-2016-04-21</b>		Author: <b>ST</b>

4. A pop-up window displays which of the two PCBs will be updated. Press “OK” and the update process starts. If the update process gets stuck for more than 5 minutes, you are probably trying to update an older model of ZQ2 that can't be updated. In this case the update procedure has no effect to the ZQ2.

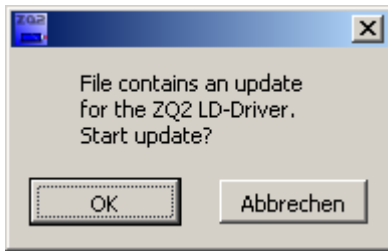

**8-21 Pop-up window**

5. Remove power to the ZQ2, wait 5 seconds and reconnect once the update is finished.

## 9 Troubleshooting Guide

Please contact Z-LASER Service.

When calling Z-LASER, please provide the customer care representative with the following information:

- Your contact Information
- Serial number or original order number
- Description of problem (i.e., hardware or software)

Ask for RMA Tracking No.

## 10 In the case of a damage

The ZQ-2 device is considered damaged when it

- does not project the correct laser pattern (e.g. line) although the everything else is working properly
- the pattern projection has obvious distortions (bright spots or scattered laser dots) and no obvious pollution of the glass covers is visible.
- the class cover of the laser sources is broken, scratched or severely contaminated
- the connectors outlet is disrupted or broken.



 Z-LASER Optoelektronik GmbH Merzhauser Str. 134 D-79100 Freiburg Tel.: (0761)29644-44 Fax: (0761)29644-55/56	Product <b>Z****Q2-F-808-Ip**</b>	Date: <b>2016.04.21</b>	Page: <b>49 of 52</b>
	Advanced Information <b>Document-ID: UI-ZL-100005-Rev0.3.10-2016-04-21</b>		Author: <b>ST</b>

- the shutter switch has a mechanical damage and problems while moving appear. (e.g. the strength needed for moving increases drastically)
- any other behaviour that is obviously not compliant to this documentation
- any other obvious mechanical damage
- system was exposed to dangerous environmental conditions (high pressure water, steam, acid or other fluid chemicals)

## 11 Errata

The following items are out of line with the confirmed target specifications:

1. USB is not functional yet, update will follow
2. Ethernet is not functional yet
3. Pattern generator only on demand

 Z-LASER Optoelektronik GmbH Merzhauser Str. 134 D-79100 Freiburg Tel.: (0761)29644-44 Fax: (0761)29644-55/56	Product <b>Z****Q2-F-808-lp**</b>	Date: <b>2016.04.21</b>	Page: <b>50 of 52</b>
	Advanced Information <b>Document-ID: UI-ZL-100005-Rev0.3.10-2016-04-21</b>		Author: <b>ST</b>

## 12 Product Labelling

This ZQ-2 device is labelled as follows.

If one of these labels is missing, or not complete, do not operate the laser.

Due to the variety of this product the laser class may vary!

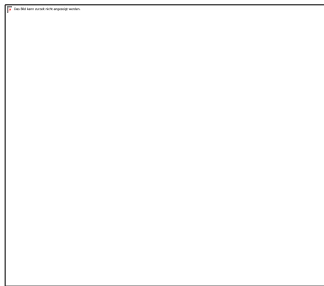

Or:

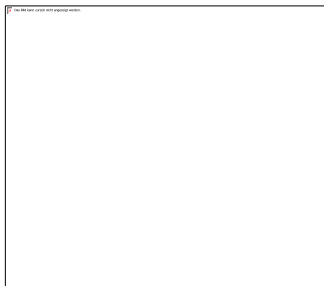

Depending on the wavelength of the laser (>790nm) the following add on is necessary

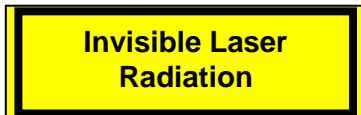

Labels may look like the following

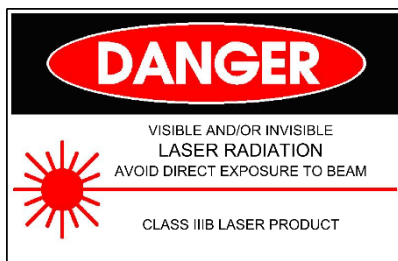

 Z-LASER Optoelektronik GmbH Merzhauser Str. 134 D-79100 Freiburg Tel.: (0761)29644-44 Fax: (0761)29644-55/56	Product <b>Z****Q2-F-808-1p**</b>	Date: <b>2016.04.21</b>	Page: <b>51 of 52</b>
	Advanced Information <b>Document-ID: UI-ZL-100005-Rev0.3.10-2016-04-21</b>		Author: <b>ST</b>

## 13 Accessories

Accessories like the following are obtainable on demand

- cooling system
- protective cover
- mountings / holders

## 14 Warranty

Z-LASER guarantees its new ZQ2 Laser series to be free of material and workmanship defects for twelve month from the date of shipment or 10,000 hours of operation (depending on the model), whichever comes first.

This warranty is in lieu of all other guarantees expressed or implied and does not cover incidental or consequential loss.

Please note that each laser may be custom built to the user's exact specifications.

Guarantee will only be granted, if the laser is shipped back in its original transportation package. (Mostly a wooden case.)

## 15 Disposal

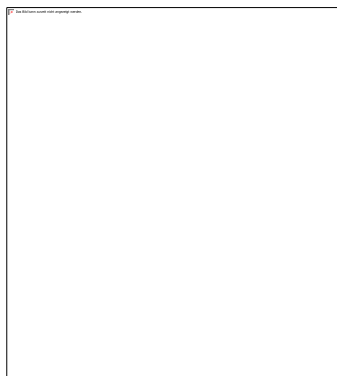

The ZQ-2 device is an electronic device that must not be disposed via ordinary waste bins.

 Z-LASER Optoelektronik GmbH Merzhauser Str. 134 D-79100 Freiburg Tel.: (0761)29644-44 Fax: (0761)29644-55/56	Product <b>Z****Q2-F-808-1p**</b>	Date: <b>2016.04.21</b>	Page: <b>52 of 52</b>
	Advanced Information <b>Document-ID: UI-ZL-100005-Rev0.3.10-2016-04-21</b>		Author: <b>ST</b>

## 16 Declaration of Conformity

(This declaration refers to the released product. Engineering samples / prototypes are shipped without full certification and might deviate from the below stated standards)

**We therefore confirm that the device described in the following**

**Name/Product:** ZQ-2 Highpower

Meet the requirements of the directive 2004/108/EC.

The product is RoHs conform and free of silicon

**The following standards were applied:**

EN 60825-1:2007  
EN 55022:2006  
EN 55011:2007

**The following guidelines were applied:**

2004/108/EC EMC-guideline  
73/23/EWG Low voltage guideline



**Z-LASER Optoelektronik GmbH**  
**Merzhauser Str. 134**  
**79100 Freiburg**

Freiburg, 21 April 2016